

# MICRODOOR™

**Erich Industries**  
**Motorized, Light-Duty**  
**Fabric Door**

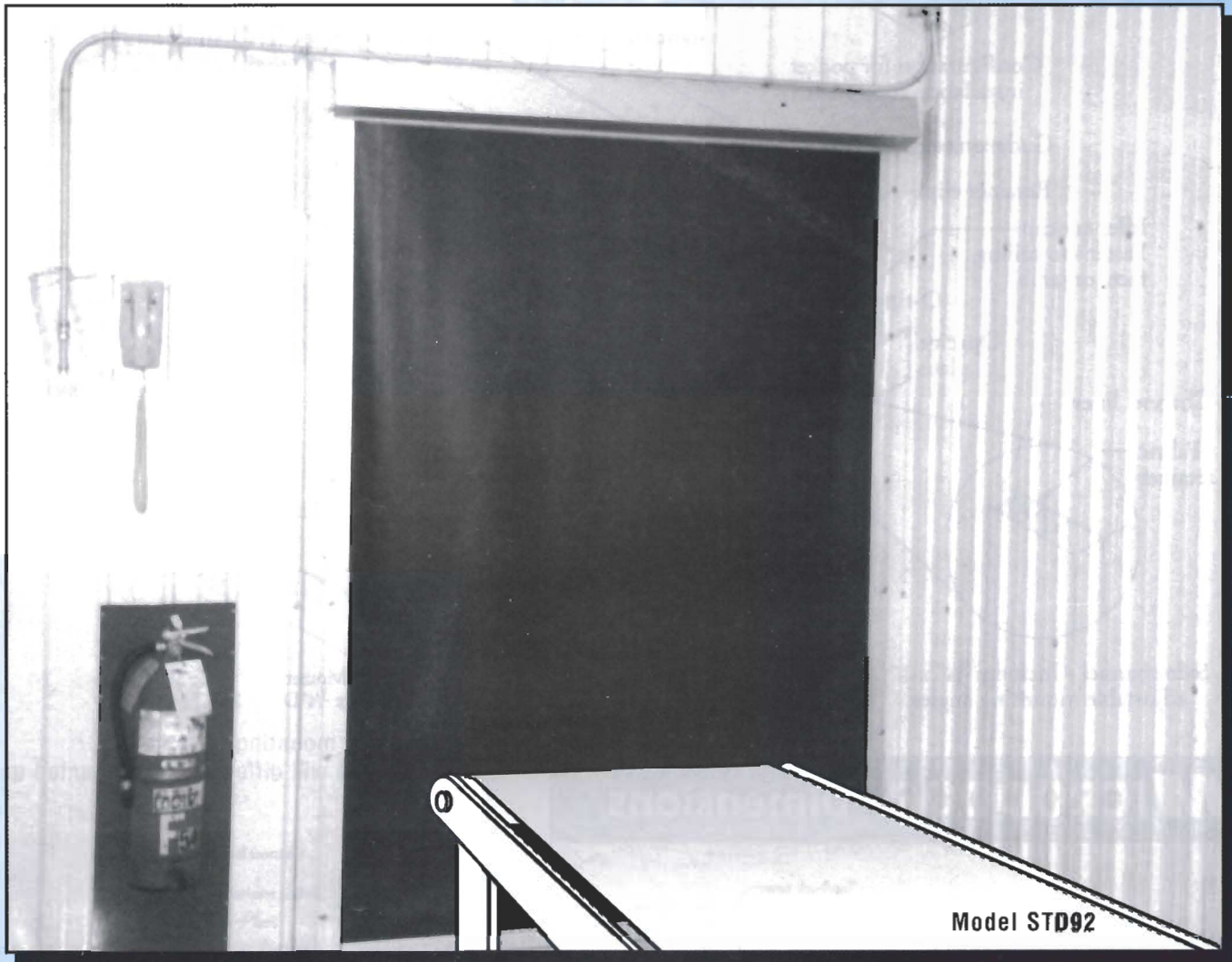

- **Automatic, vertical movement for efficient workflow and operation on conveyor passageways or other locations where a smaller fabric roll-up door is required.**
- **Tight perimeter seal minimizes thermal penetration on coolers or between other environmentally controlled locations.**
- **Simple design provides ease of operation and quick installation.**
- **Available in a wide variety of colors.**
- **Extreme tight side and header clearances for applications with a minimum of mounting space. In addition, the narrow profile allows for mount between conveyor segments.**
- **Patented Fabric Retention System provides additional rigidity where slight pressure exists.**



Performance Products Division  
1078 Bluff City Blvd.  
Elgin, IL 60120  
(800) 882-5839  
Fax (847) 608-0050

# Components for a Complete MICRODOOR™ System

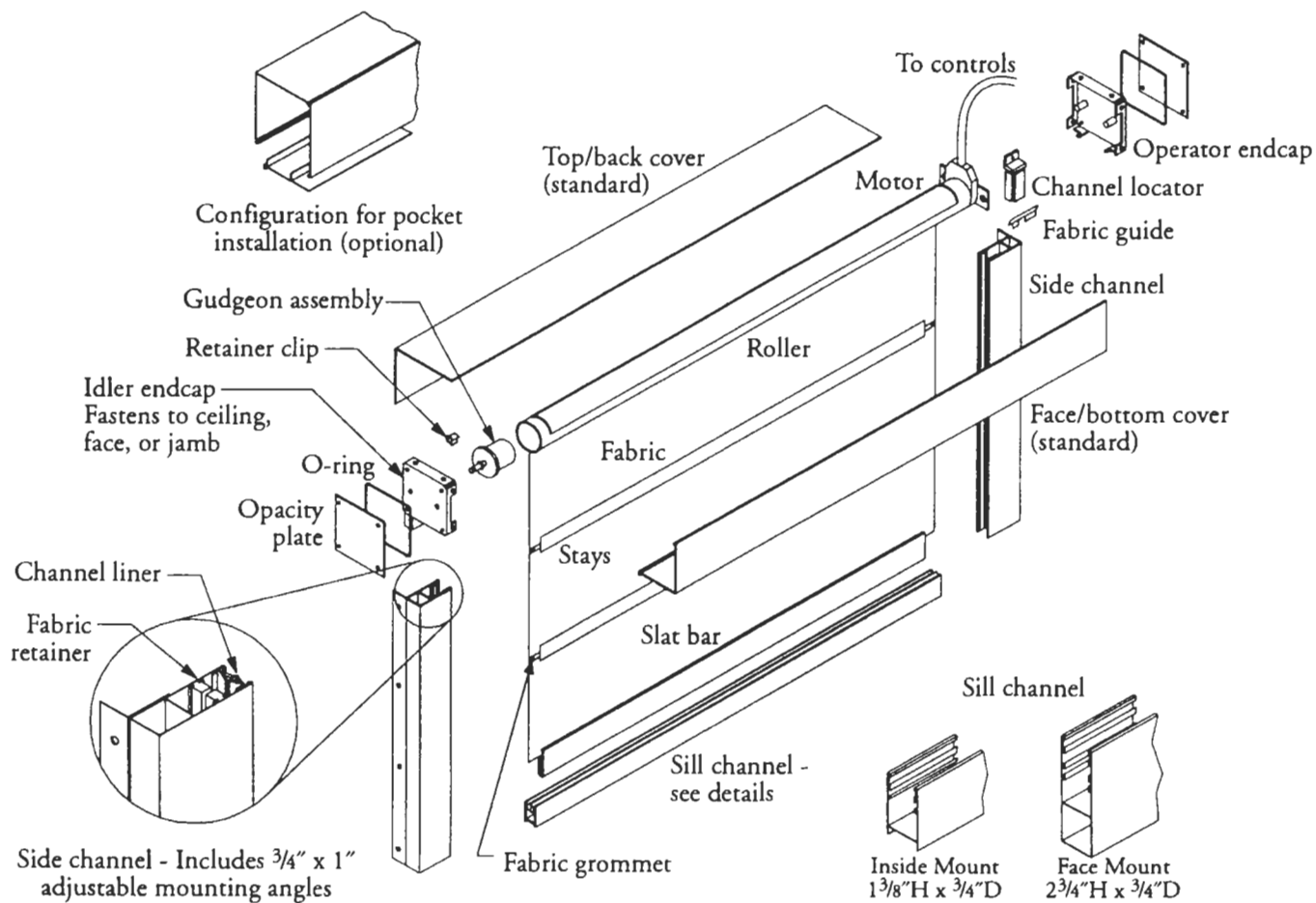

Inside mounting style shown.  
Details will differ for face-mounted units.

## MICRODOOR™ Dimensions

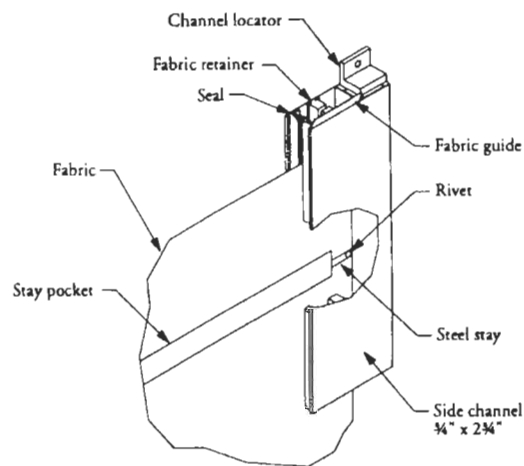
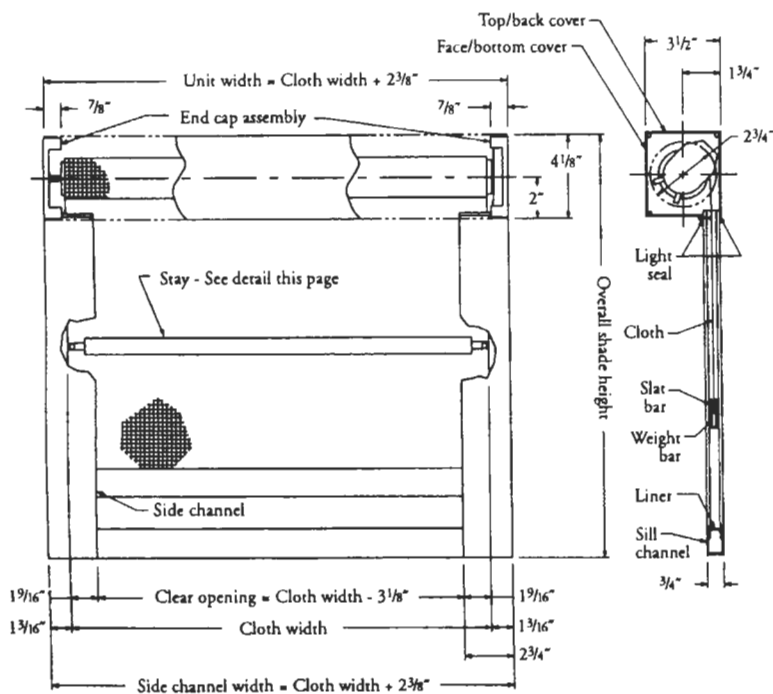

Patented Fabric Retention System: steel stays placed at regular intervals and covered; grommets at each end hold fabric in side channels (standard).

Distributed By:

**Call ERICH Industries  
at 1-800-882-5839**