

# DH400

## High Mount Active Infrared Presence Detector for Automatic Door Control **INSTALLATION INSTRUCTIONS**

**NOTE:** Set up for this sensor should be performed by an AAADM-certified installer.

### Section 1

#### General Description

The DH400 is a high mount microprocessor controlled active infrared presence detector for all types of automatic doors.

- Wide and narrow pattern width of the sensor is adjustable.
- Pattern depth and width are adjustable using mounting height, dip switches, pattern width and pattern angle adjustments.
- Frequency is selectable in four channels
- Self-Diagnostic means the sensor continuously monitors itself.
- Snow Mode Switch ensures against false operation caused by snow, insects, etc.
- Microprocessor provides programmable Presence Timer (2 sec., 30 sec., 60 sec., or infinity).



### Section 2

#### Parts Identification

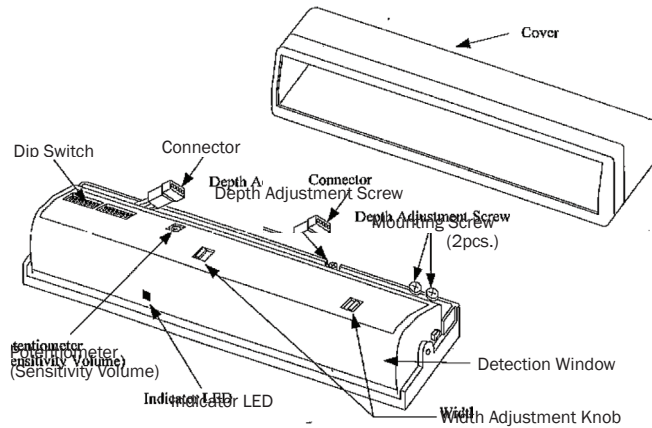

#### Accessories

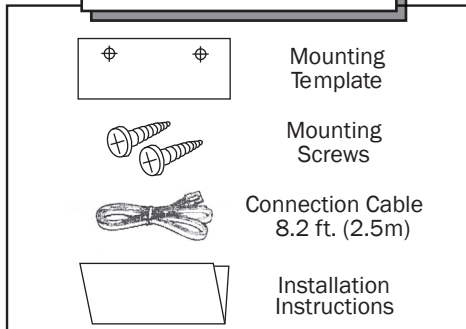

### Section 3

#### Mounting Information

1. Do not mount higher than 13.1 ft. (4m).
2. Mount within 1.97" from the bottom of the door engine cover.
3. Do not leave any objects which may move in the detection pattern.
4. Do not mount in a humid or steamy environment.
5. Do not mount where rain or snow will fall directly on unit.
6. Do not mount where snow or water will accumulate on floor if possible.
7. Do not mount in a place where reflection of sunlight will shine on unit.
8. Use different frequency settings for sensor in close proximity.

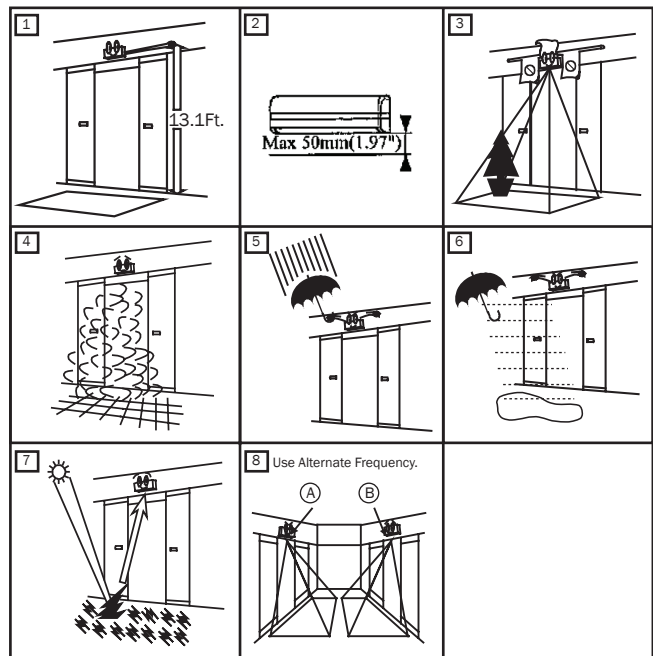

To maximize the effectiveness of doorway detection, install the DH400 outside and inside as shown below.

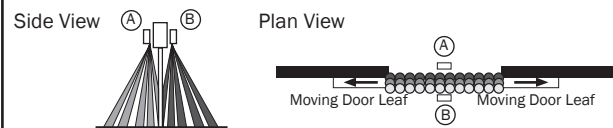

# DH400

## High Mount Active Infrared Presence Detector for Automatic Door Control **INSTALLATION INSTRUCTIONS**

### Section 4

#### Mounting and Wiring

1. Using the mounting template provided, drill mounting and wire holes.

2. Remove cover of unit.

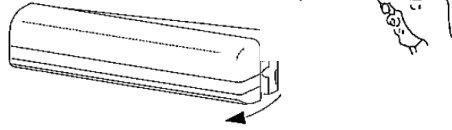

3. Fasten unit with mounting screws provided.

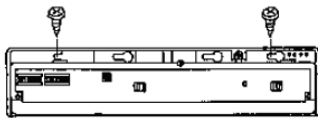

4. Connect wiring. Push amp connectors tightly together.

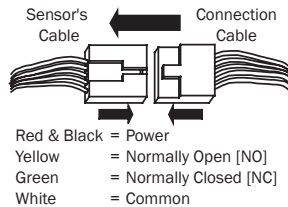

5. House connectors in the receptacle.

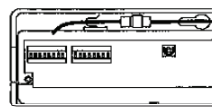

6. Replace cover.



### Section 5

#### Dip Switch Settings

##### Dip Switch X

Dip Switches are depicted in the Default position. \* = Default

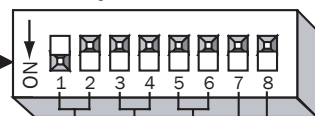

Presence Timer	Frequency	Pattern Depth (Rows)	Monitor Mode
2 Sec <input type="checkbox"/> <input type="checkbox"/>	*A <input type="checkbox"/> <input type="checkbox"/>	*5R <input type="checkbox"/> <input type="checkbox"/> <input type="checkbox"/> <input type="checkbox"/> <input type="checkbox"/> <input type="checkbox"/> <input type="checkbox"/> <input type="checkbox"/> <input type="checkbox"/> <input type="checkbox"/>	*Normal <input type="checkbox"/> <input type="checkbox"/>
*30 Sec <input type="checkbox"/> <input type="checkbox"/>	B <input type="checkbox"/> <input type="checkbox"/>	4R <input type="checkbox"/> <input type="checkbox"/> <input type="checkbox"/> <input type="checkbox"/> <input type="checkbox"/> <input type="checkbox"/> <input type="checkbox"/> <input type="checkbox"/> <input type="checkbox"/> <input type="checkbox"/>	Snow 1 <input type="checkbox"/> <input type="checkbox"/>
60 Sec <input type="checkbox"/> <input type="checkbox"/>	C <input type="checkbox"/> <input type="checkbox"/>	3R <input type="checkbox"/> <input type="checkbox"/> <input type="checkbox"/> <input type="checkbox"/> <input type="checkbox"/> <input type="checkbox"/> <input type="checkbox"/> <input type="checkbox"/> <input type="checkbox"/> <input type="checkbox"/>	Snow 2 <input type="checkbox"/> <input type="checkbox"/>
∞ Sec <input type="checkbox"/> <input type="checkbox"/>	D <input type="checkbox"/> <input type="checkbox"/>	2R <input type="checkbox"/> <input type="checkbox"/> <input type="checkbox"/> <input type="checkbox"/> <input type="checkbox"/> <input type="checkbox"/> <input type="checkbox"/> <input type="checkbox"/> <input type="checkbox"/> <input type="checkbox"/>	Snow 3 <input type="checkbox"/> <input type="checkbox"/>
① ②	③ ④	⑤ ⑥ * 5 R R R R	⑦ ⑧

①&② **Presence Timer:** The sensor will detect a stationary object for the time period set by the Presence Timer. The timer will reset and begin if **any** movement is detected.

③&④ **Frequency:** When more than two sensors are used in close proximity to each other, to prevent interference use alternate frequency settings.

⑤&⑥ **Pattern Depth (Rows):** To adjust the pattern depth, set switches 3 & 4 as shown.

⑦&⑧ **Monitor Mode:** A Snow Mode is available. Snow Mode should only be used in environments with heavy snowfall or other extreme conditions.

##### Dip Switch Y

Dip Switches are depicted in the Default position. \* = Default

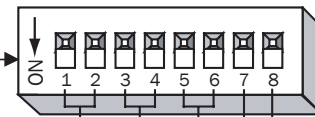

Pattern Width (Left)	Pattern Width (Right)	Installation Height	Direction Detection	Doorway Learn
*R6 <input type="checkbox"/> <input type="checkbox"/>	*R6 <input type="checkbox"/> <input type="checkbox"/>	*6.6' - 8.2' <input type="checkbox"/> <input type="checkbox"/>	*Off <input type="checkbox"/> <input type="checkbox"/>	*Off <input type="checkbox"/> <input type="checkbox"/>
R4 <input type="checkbox"/> <input type="checkbox"/>	R4 <input type="checkbox"/> <input type="checkbox"/>	8.2' - 9.8' <input type="checkbox"/> <input type="checkbox"/>	On <input type="checkbox"/> <input type="checkbox"/>	On <input type="checkbox"/> <input type="checkbox"/>
R2 <input type="checkbox"/> <input type="checkbox"/>	R2 <input type="checkbox"/> <input type="checkbox"/>	9.8' - 11.5' <input type="checkbox"/> <input type="checkbox"/>	On <input type="checkbox"/> <input type="checkbox"/>	On <input type="checkbox"/> <input type="checkbox"/>
R2 <input type="checkbox"/> <input type="checkbox"/>	R2 <input type="checkbox"/> <input type="checkbox"/>	11.5' - 13.1' <input type="checkbox"/> <input type="checkbox"/>	On <input type="checkbox"/> <input type="checkbox"/>	On <input type="checkbox"/> <input type="checkbox"/>
① ②	③ ④	⑤ ⑥	⑦	⑧

①&② **Pattern Width (Left Side):** The left side detection area for approaching direction can be fixed by setting to 6, 4 or 2 rows.

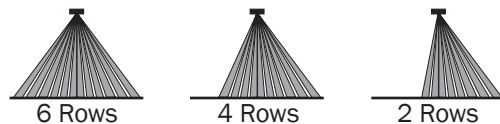

③&④ **Pattern Width (Right Side):** The right side detection area for approaching direction can be fixed by setting to 6, 4, or 2 rows.

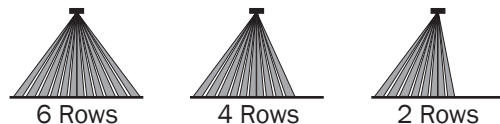

⑤&⑥ **Installation Height:** Set to installation height required.

**NOTE:** Set the sensitivity after setting the mounting height. Refer to **Section 8: Verification of Operation** regarding the standard of sensitivity corresponding to mounting height.

# DH400

## High Mount Active Infrared Presence Detector for Automatic Door Control **INSTALLATION INSTRUCTIONS**

- ⑦ **Direction Detection:** When set to ON, pedestrians moving away from the sensor will NOT be detected.  
**NOTE:** For pedestrian safety purposes when “Doorway Learn” is set to ON, the 1st and 2nd row of detection will detect pedestrians regardless of direction of movement.
- ⑧ **Doorway Learn:** Allows the 1st row of detection to be focused inside the door close area without detecting the door movement.  
**NOTE:** When “Doorway Learn” is turned ON, the sensitivity level of the 1st row of detection is at maximum only when the outer rows of detection are activated.

### Section 6

#### Power & “Doorway Learn” Setting

##### BEFORE APPLYING POWER, READ AND FOLLOW THESE INSTRUCTIONS:

When power is applied, the sensor will read and store the environmental optical parameters. This is necessary for Presence Detection to work properly.

1. CLEAR THE AREA OF ANY UNNECESSARY OBJECTS.
2. Apply POWER.
3. Vacate the Detection Pattern immediately. While the sensor sees ANY moving objects in its DETECTION PATTERN, it will not proceed to the following step.
4. DO NOT enter DETECTION PATTERN for 10 seconds (Presence Detection Setting).
5. TEST the presence feature, especially near the door.

When carrying out the following work, TURN OFF THE POWER:

1. When the floor conditions change.
2. Adjusting pattern or sensitivity.

##### “DOORWAY LEARN” is OFF

(Ref. Sec. 5-Dip Switch Settings)

- Upon power ON, the solid Green LED turns on indicating that the sensor is in standby mode and ready to detect.

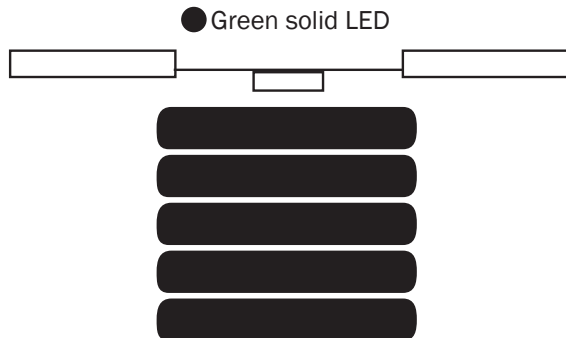

##### “Doorway Learn” is OFF (Cont.)

Presence Detection: It takes 10 seconds after the sensor powers up for presence detection to be initiated on all rows of detection. If someone enters the detection area before 10 seconds has elapsed, the sensor will continue to initialize until after 5 seconds with no motion being detected.

##### “DOORWAY LEARN” is ON

(Ref. Sec. 5-Dip Switch Settings)

- Upon power ON, the Red LED indicates a door open relay output to begin the “Doorway Learn” process.

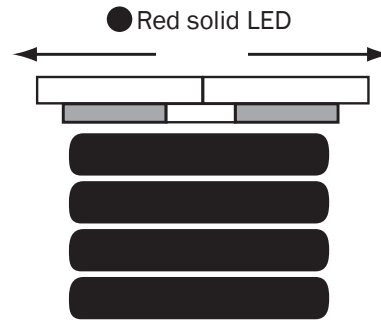

- Green LED blinks for 37 seconds while the “Doorway Learn” process is carried out. Door opens/closes.

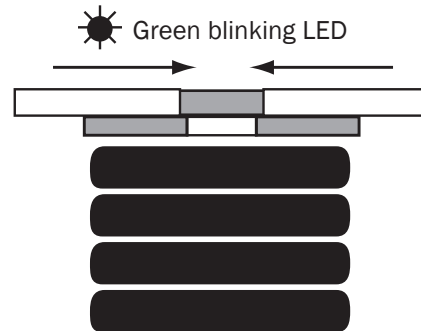
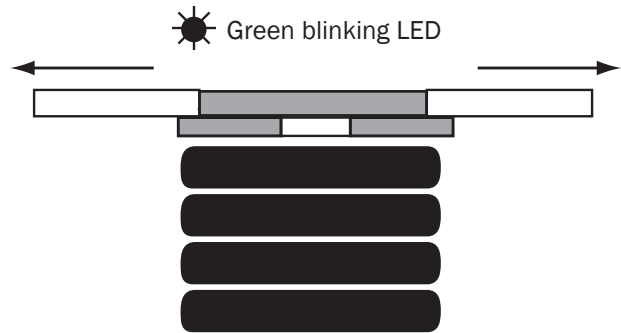

# DH400

## High Mount Active Infrared Presence Detector for Automatic Door Control **INSTALLATION INSTRUCTIONS**

- After the “Doorway Learn” process is completed, sensor is in standby mode.

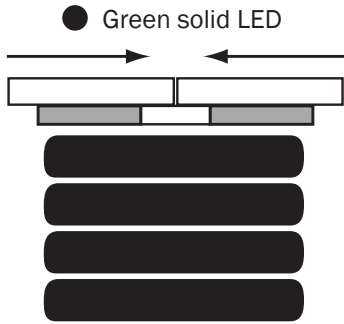

**Presence Detection:** During the “Doorway Learn” process, the outer 4 rows of detection on the DH400 sensor switch from motion detection to presence detection 10 seconds after power ON. The inner “Doorway Learn” row of detection will switch from motion to presence detection after the “Doorway Learn” process is complete.

**“Doorway Learn” Failure & Recovery:** If a person enters the detection area during the “Doorway Learn” process, it may not be successfully completed. In this case, the sensor will carry out the “Doorway Learn” process on door activation caused by a person in order to build an accurate image of the door open and door close position.

**NOTE:** When “Doorway Learn” is turned ON, the sensitivity level of the inner row of detection is at maximum ONLY when the outer rows of detection are activated.



**CAUTION:** If you change dip switch setting or sensitivity volume, the sensor will be reest. During resetting, indicator LED is blinking with orange color. Keep away from detection area. After resetting, the sensor becomes the same state as it is turned Power-on.

In case the product is used as a supplementary sensor: Set the detection area of the 1st row away from the door.

### Section 7

#### Adjusting Detection Pattern

Adjust the detection pattern according to the following diagrams:

1. Pattern Angle Adjustment.

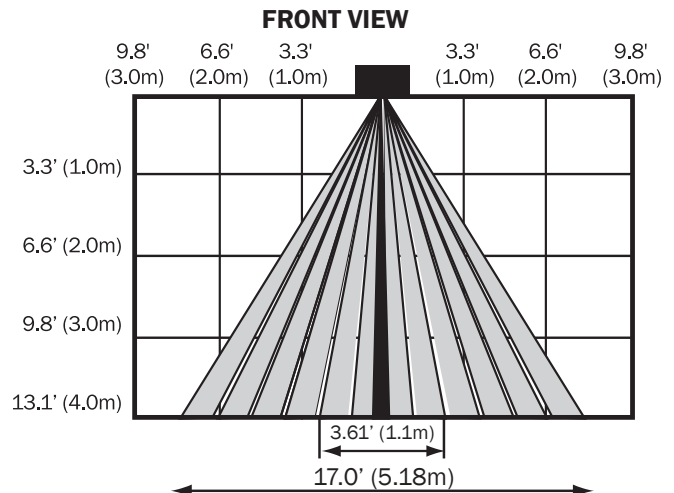
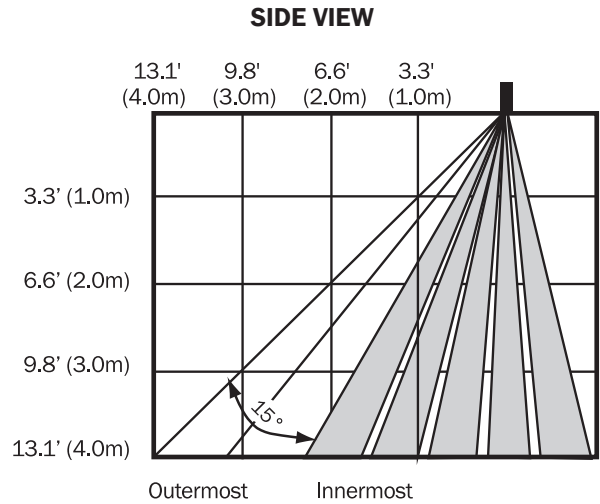

# DH400

## High Mount Active Infrared Presence Detector for Automatic Door Control **INSTALLATION INSTRUCTIONS**

### 2. Pattern Width Adjustment.

Pattern Adjustments for single and/or double doors.

#### OUTER MOST

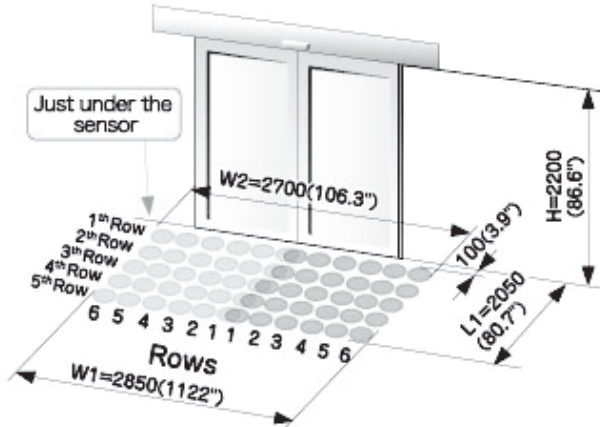

#### INNER MOST

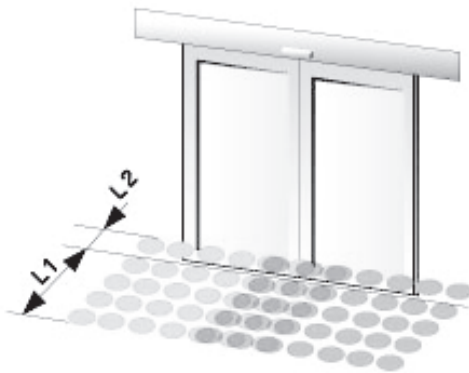

Unit: mm(inches)

H	Outermost detection area			Innermost detection area			
	W1	W2	L1	W1	W2	L1	L2
2000 (78.7")	2590 (102.0")	2450 (94.5")	1860 (73.2")	2180 (85.8")	2360 (92.9")	1130 (44.4")	-500 (19.7")
2200 (86.6")	2850 (112.2")	2700 (106.3")	2050 (80.7")	2400 (94.5")	2600 (102.4")	1250 (49.2")	-550 (21.7")
2500 (98.4")	3230 (127.2")	3060 (120.5")	2330 (91.7")	2720 (107.1")	2950 (116.1")	1420 (55.9")	-620 (24.4")
3000 (118.1")	3880 (152.8")	3680 (144.9")	2790 (109.8")	3270 (128.7")	3540 (139.4")	1700 (66.9")	-750 (29.5")
3500 (137.8")	4530 (178.4")	4290 (168.9")	3260 (128.4")	3810 (150.0")	4130 (162.6")	1980 (78.0")	-870 (34.3")
4000 (157.5")	5180 (203.9")	4900 (192.9")	3720 (146.5")	4360 (171.7")	4720 (185.8")	2260 (89.0")	-1000 (39.4")

See **Section 5: Dip Switch Settings** for details on dip switch settings adjustments for Detection Depth and Width.

Further depth adjustments can be made using the Depth Adjustment Screw. Rotate clockwise to obtain outermost setting of 15°. Rotate counter-clockwise to adjust minimum/innermost setting to 0°.

#### Depth Adjustment Screw

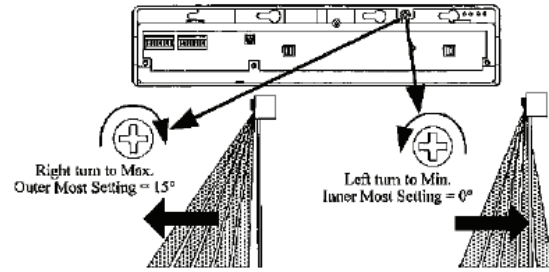

### Section 8

#### Verification of Operation

1. After mounting, setting parameters and applying power, walk test unit to verify detection pattern.
2. If the door does not operate properly, recheck the dip switch settings and pattern adjustments.
3. After rechecking, if there is still a problem, adjust the sensitivity.

- Adjust high (clockwise) to increase sensitivity.
- Adjust low (counter-clockwise) to decrease sensitivity.

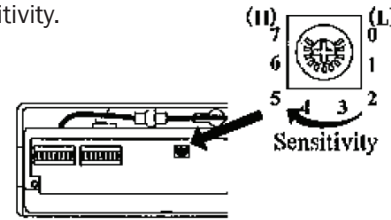

Standard of sensitivity volume setting depending on Mounting Height:

Height Setting	Setting Standard
6.6' (2.0m) - 8.2' (2.5m)	4
8.2' (2.5m) - 9.8' (3.0m)	5
9.8' (3.0m) - 11.5' (3.5m)	*6
11.5' (3.5m) - 13.1' (4.0m)	7

### Section 9

#### Self Monitoring

When the sensor has an internal sensor error, the door will remain open and the Green/Red LED blinks alternately.

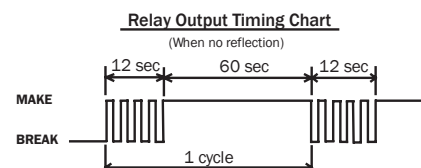



# DH400

## High Mount Active Infrared Presence Detector for Automatic Door Control **INSTALLATION INSTRUCTIONS**

### Self Monitoring (cont.)

**\*\*\*\*\*EXTREMELY IMPORTANT\*\*\*\*\***

*After final set-up, test unit(s) completely to ensure that proper coverage has been achieved (width, depth and location of the pattern must be tested).*

After the installation and operational check of the system:

1. Place the proper labels on the door per ANSI/BHMA A156.10 & BS 7036.
2. Instruct the owner of the door system operation and how to test it. This should be checked on a daily basis.
3. Instruct the owner on what to do if the door or any of its components become damaged.
4. Strongly recommend to the owner that the complete entry be inspected twice a year as part of the service agreement.

### Section 10

#### Troubleshooting

PROBLEM 1: Door does not open

LED STATUS: Off

CAUSE 1: Sensor Connector

SOLUTION 1: Tighten connector or reconnect

CAUSE 2: Power Supply

SOLUTION 2: Check that the power supply is properly connected and 12V to 24V AC or DC

CAUSE 3: Sensor Wiring

SOLUTION 3: Double check sensor wiring.

PROBLEM 2: Door operates by itself (ghosting)

LED STATUS: Door Opens=RED, Door Closes=Green

CAUSE 1: There is an object moving in the detection area

SOLUTION 1: Remove the moving object from detection area

CAUSE 2: Sensitivity too high

SOLUTION 2: Turn down sensitivity

CAUSE 3: Dust, frost or water droplet on the sensor lens

SOLUTION 3: Wipe sensor lens with clean cloth and install a weather cover if necessary

CAUSE 4: Detection pattern is too far from the door, detecting people passing by

SOLUTION 4: Adjust detection pattern

CAUSE 5: Detection area overlaps with that of another sensor

SOLUTION 5: Ensure different frequency setting for each sensor

CAUSE 6: Detection of falling snow, insects, leaves, etc.

SOLUTION 6: Adjust the Monitor Mode

PROBLEM 3: When door opens or closes, LED ORANGE  
LED STATUS: ORANGE

CAUSE 1: Detection row "ROW 1" ("ROW 2" when "Doorway Learn" is turned ON) is focused too close to the door

SOLUTION 1: Adjust detection depth of rows away from the door

PROBLEM 4: Door opens and remains in the open position

LED STATUS: RED

CAUSE 1: Detection area changed, while infinity presence timer setting is in use

SOLUTION 1: Repower the sensor or change the presence timer settings to 30 or 60 seconds

CAUSE 2: Incorrect Sensor Wiring

SOLUTION 2: Double check sensor wiring

CAUSE 3: Reflected Signal Saturation

SOLUTION 3: Remove highly reflective objects from the detection area, or lower the sensor sensitivity

LED STATUS: GREEN/RED FLASH

CAUSE 1: Internal Sensor Error

SOLUTION 1: Replace the sensor

# DH400

## High Mount Active Infrared Presence Detector for Automatic Door Control **INSTALLATION INSTRUCTIONS**

### Section 11

#### Technical Data

Model.....	DH400 Presence Detector
Detection Method.....	Active Infrared Reflection
Max. Installed Height.....	13.1 ft. (4.0m)
Pattern Adjustments.....	Pattern Width Pattern Depth (up to 6 rows) Angle Adjustment 0° to 15°
Detection Beams.....	16 Beams*5 Rows=60 Beams
Power Supply.....	12 to 24 V AC or DC ± 10%
Power Consumption.....	AC24V-2.5VA, AC12V-2.5VA DC24V-65mA, DC12V-140mA
Output Contact.....	Form C Relay: DC50V 0.1A (Resistor Load)
Output Holding Time.....	Approx. 0.5 seconds
Response Time.....	0.1 seconds
Presence Timer.....	2 sec., 30 sec., 60 sec., or infinity (∞)
LED Indication.....	RED = Detecting GREEN = Standby GREEN BLINKING - Doorway Learning (when dip switch $\text{Y}$ 8 is ON) ORANGE = Detection row "ROW 1 ("ROW 2" when "Doorway Learn" is turned ON) is detecting door movement ORANGE BLINKING = Indicates a change of dip switch settings or sensitivity volume GREEN/RED BLINKING = Internal Sensor Error
IP Rating.....	IP54 (with base)
Temperature Range.....	-4° F to 140° F (-20° C to 60° C)
Operating Humidity.....	Below 80%
Weight.....	0.64 lbs. (0.29kg)
Color.....	Black, Silver
Accessories.....	Cable: 8.2 ft. (2.5m) Mounting Template Installation Instructions

### Section 12

#### External Dimensions

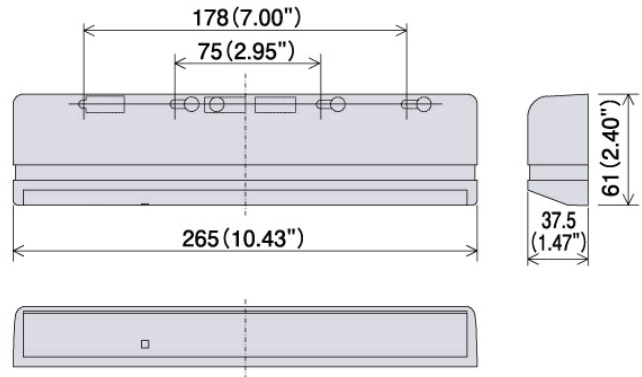

### Section 13

#### Warranty

MS SEDCO guarantees this product to be free from manufacturing defects for 3 years from date of installation. Unless MS SEDCO is notified of the date of installation, the warranty will be in effect for 3 years from the date of shipment from our factory. If, during the first 3 years, our motion detector or support device fails to operate and has not been tampered with or abused, the unit can be returned prepaid to factory and it will be repaired free of charge. After 3 years, the unit will be repaired for a nominal service charge. **This limited warranty is in lieu of all other warranties expressed or implied, including any implied warranty of merchantability, and no representative or person is authorized to assume for MS SEDCO any other liability in connection with the sale of our products. All warranties are limited to the duration of this written warranty. In no event shall MS SEDCO be liable for any special, incidental, consequential or other damages arising from any claimed breach of warranty as to its products or services.**