

SSS-5

Door Mounted Presence Sensor

INSTALLATION INSTRUCTIONS

Section 1

General Description

The SSS-5 is a door mounted presence sensor designed to provide safety protection for automatic swing doors. The SSS-5 combines the most reliable active infrared technology available with Position Sensitive Detection (PSD) technology found in auto focus cameras to ensure precise pedestrian detection within the path of a moving door panel.

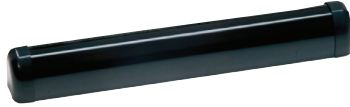

The SSS-5 mounts near the top of the door panel out of harms way. PSD sensor technology automatically focuses the sensor lenses to dip switch controlled height settings. Pattern width can be adjusted by inserting additional PCB Sensor Units into the 27 1/4" long extruded aluminum housing, allowing the detection zone of each module to be adjusted independently.

Each PCB Sensor Unit consists of a transmitter (TX) and a receiver (RX) that transmit a precise detection pattern that functions independently of other modules. The SSS-5M1 contains a single PCB Sensor Unit and is ideal for low energy doors. The SSS-5L2 contains two PCB Sensor Units doubling the detection capability of the SSS-5 providing safety for full energy doors.

Section 2

Parts Identification

Components Diagram

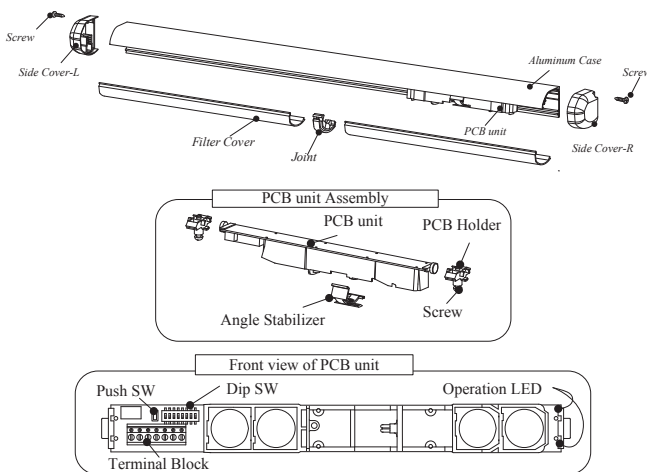

SSS-5 Options:

SSS-5M1: 34.75" L (911mm); 1 PCB; 1 Sensor

Accessories

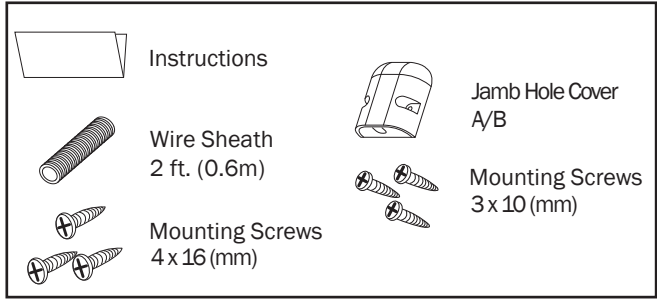

Section 3

Mounting Information

1. Do not mount higher than 8' 6" (2.6m).
2. Ensure rain or snow will not fall directly on unit.
3. Ensure a minimum of reflected sunlight from floor.
4. Avoid steamy environments.
5. The Aluminum Case should be located close to leading edge of door to maximize safety detection.

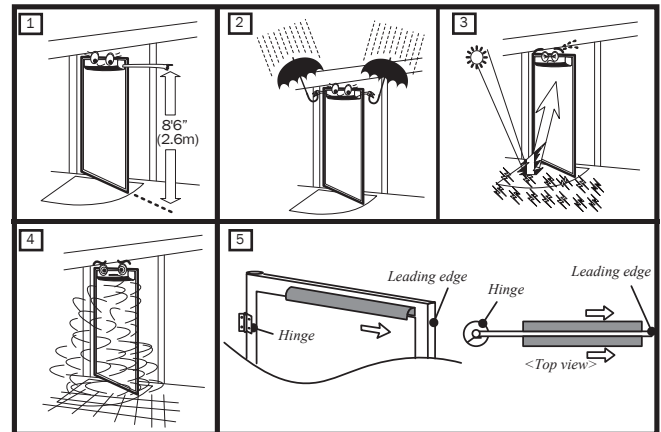

Section 4

Installation and Wiring

Drill Mounting holes as illustrated below. When installing the SSS-5 on both sides of the door, it may be necessary to drill a wiring hole through the door.



WARNING:
Drilling may cause
Electric Shock.

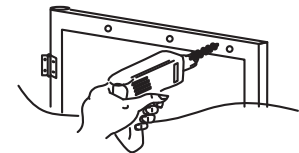

SSS-5M1

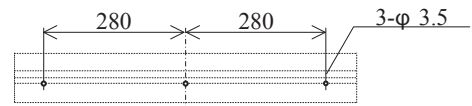

SSS-5

Door Mounted Presence Sensor

INSTALLATION INSTRUCTIONS

Section 4

Installation and Wiring (continued)

1. Unscrew and remove the End Caps and then the Filter Cover from the Housing.

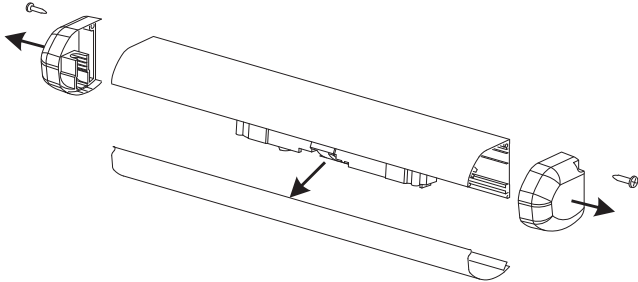

2. Remove Angle Stabilizers by lifting and sliding them to the end of the Housing then push with your thumb to remove them completely.

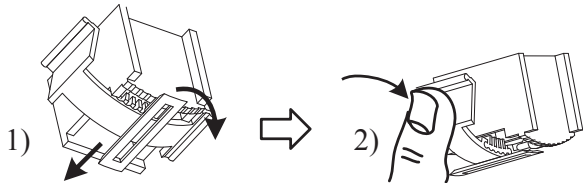

3. Remove each PCB Holder by loosening the screws and sliding them and the PCB Sensor Units out of the Housing. The Housing should now be empty.

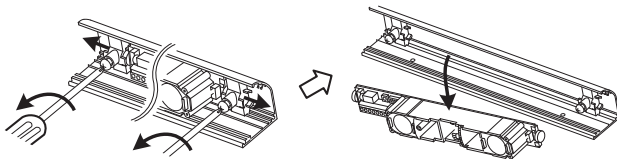

4. Attach the Aluminum Housing to the door using it as a template to drill the 3 mounting holes. When installing an SSS-5 on both sides of the door, a wiring thru hole is necessary.

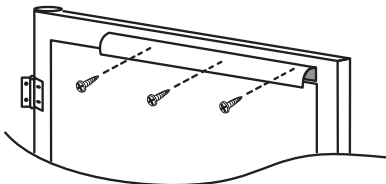

NOTICE: When replacing the PCB unit, mount the Housing as close to the leading edge of the door as possible.

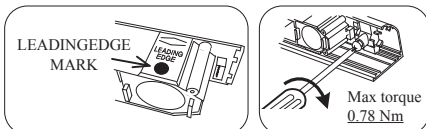

5. Remove the main cable Terminal block from the "hinge side" of the PCB unit.



6. Replace the first PCB Holder by sliding it into the Housing and fixing it in position (do not overtighten the screw). Then slide the PCB Sensor Units into the Housing with the "TX" lens closest to the leading edge of the door.

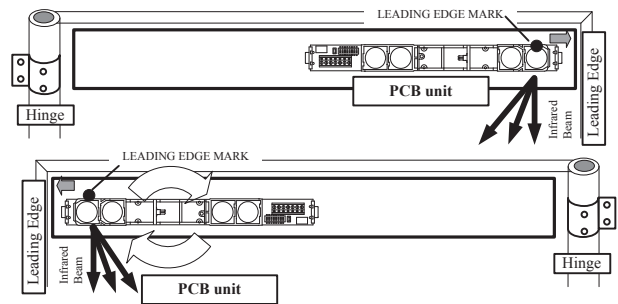

7. Install the Jamb Hole Cover on the hinge side of the door frame parallel to where the SSS-5 is mounted. Pull four 24 gauge wires from the operator control to the main Terminal Block location on the hinge side PCB Sensor Unit **including an additional 24" of extra length of each wire between the Jamb Hole Cover and the SSS-5**. Feed the wires through the Wire Sheath and then clamp it between the Jamb Hole Cover A/B Covers.

Drill following holes.

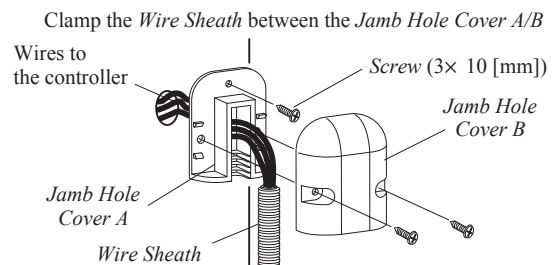
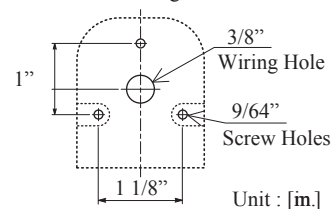

SSS-5

Door Mounted Presence Sensor

INSTALLATION INSTRUCTIONS

Section 4

Installation and Wiring (continued)

- Remove the main Cable Terminal Block from the **hinge side** PCB Sensor Unit and attach the four wires to it. Reconnect the main Terminal Block to the hinge side PCB Sensor Unit.

WARNING: Connect the wires to the door controller using the Terminal Block.

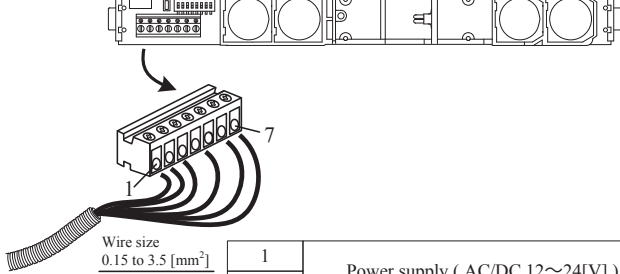

Wire size
0.15 to 3.5 [mm²]

1	Power supply (AC/DC 12~24[V])
2	
3	Relay Output (Common)
4	Relay Output (Normal Open)
5	Relay Output (Normal Close)
6	TEST Input (-)
7	TEST Input (+)

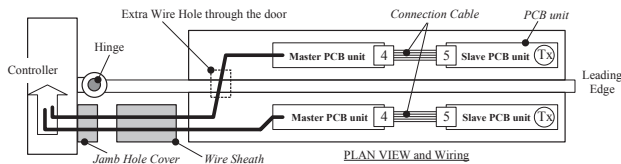

Section 5

Setup and Adjustment

- Dip Switch Settings:** 4 Dip Switches are available on each PCB Sensor Unit and they all must be set for the SSS-5 to function properly.

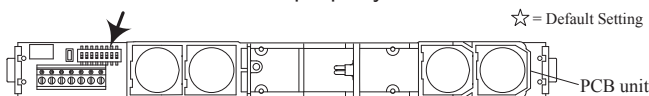

☆ = Default Setting

Dip Switch #1 = TEST Input

When connected to a door controller without a TEST input, set to "OFF". When connected to a door controller with a TEST input, set to "ON". Refer to Timing Chart of Events on page 4.

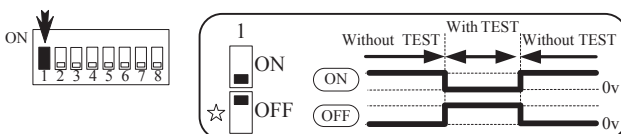

Dip Switch #2 = Optical Interference

When two SSS-5s are installed in close proximity, optical cross interference between the devices may result. To prevent this set different frequency settings.

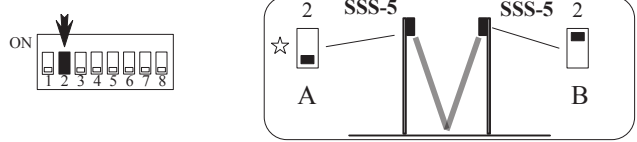

Dip Switch #3 = Relay Output Hold Time

This is the length of time the relay will hold "on" after detection is lost.



Dip Switch #4 + 5 = Mask Detecting Spots

Relay output options are N.O. (Normally Open) or N.C. (Normally Closed)

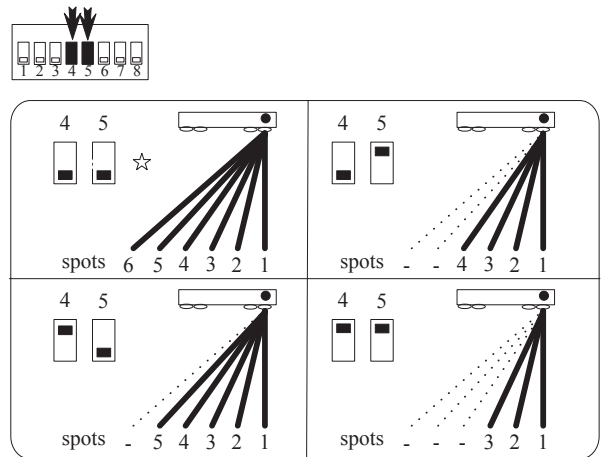

Section 5

Setup and Adjustment (continued)

Dip Switch #5, 6 + 7 = Detection Range: The Detection Range must be set on all PCB Sensor Units.

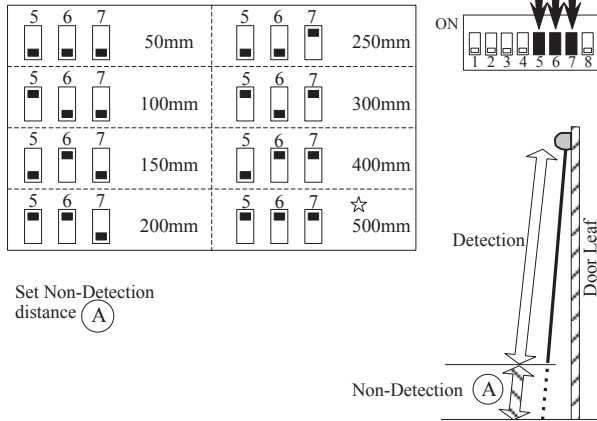

2. **Detection Angle Adjustment:** The detection angle can be adjusted between 5° and 25° in 5° increments using the Angle Stabilizer.

(Example) Changing angle from 5° to 25°

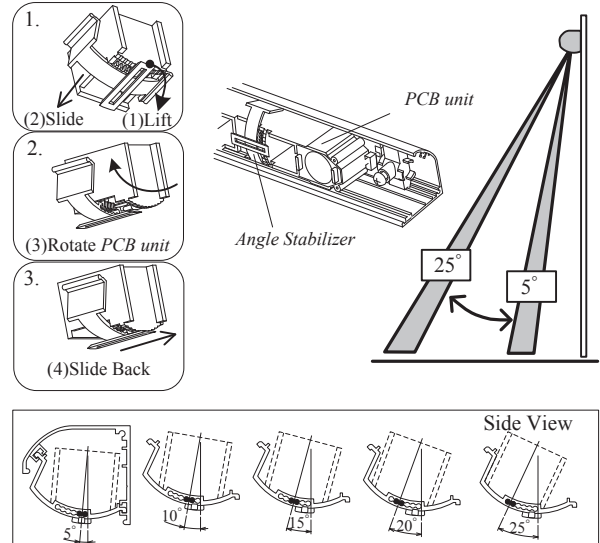

3. Timing Chart of Events

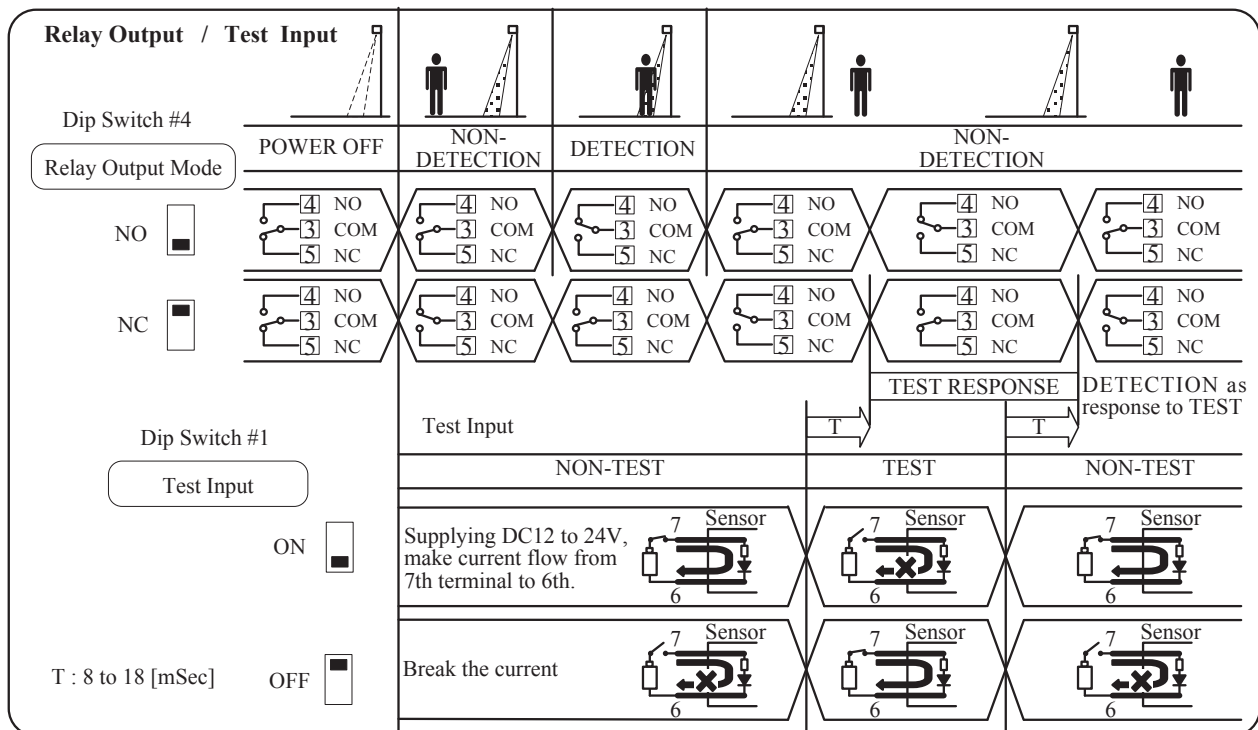

Section 5

Setup and Adjustment (continued)

4. **LED Indicator Information:** The Operation LED turns **OFF** when each PCB Sensor unit detects a person.

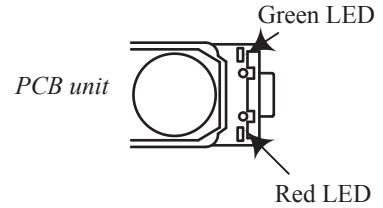

Normal State	State	Red LED	Green LED
	Non-Detect	○ OFF	⚙ ON
	Detect	⚙ ON	○ OFF

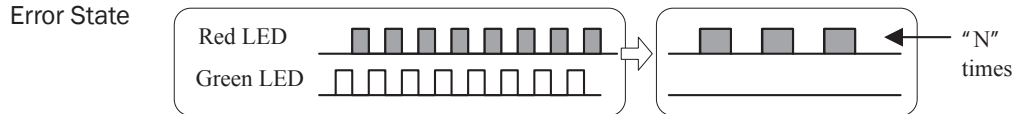

N	Error category	Cause	Solution
1	Environmental error	Noise occurs on setting environment. The reflection level of the floor is low.	Execute "TEACH" of the Section 8 laying a sheet of white paper on the floor of the detection area.
3 over	Other Error	Internal component failure	Change the units.

5. **Teaching:** The following steps must be conducted without the Filter Cover.
- Check the wiring connection and power supply
 - Execute "TEACHING". "TEACHING" is necessary make the sensor work properly (that is to learn the number of sensor units and the distance from a floor).

STEP 1: Press the "Push SW" of the master unit for more than 2 seconds.

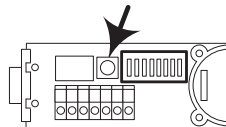

STEP 2: LED blinks slowly for 10 seconds in a non-detection state. Remove the person or object(s) within the detection area during this time.

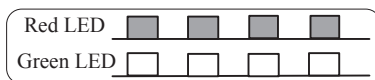

STEP 3: After STEP 2, LED blinks faster and starts "TEACHING". If, during this period, a person or moving object is in the area, try again from STEP 1.



STEP 4: After LED stops blinking, the number of sensor units is indicated.

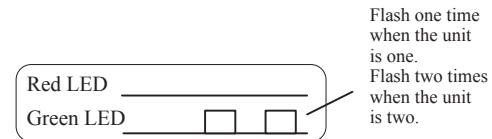

NOTE: If the number of units installed and the time(s) the LED flashed are not the same, check tnection of cable, and retart "TEACHING".

- Check the adjustments, range and other setting.

SSS-5

Door Mounted Presence Sensor

INSTALLATION INSTRUCTIONS

Section 5

Setup and Adjustment (continued)

6. Detection Area:

TOP VIEW

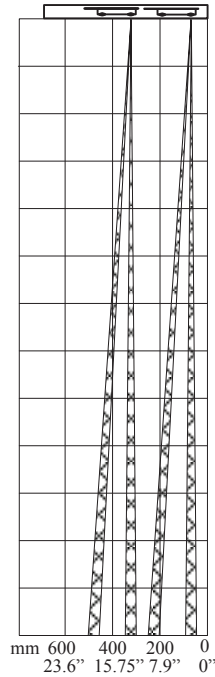

SIDE VIEW

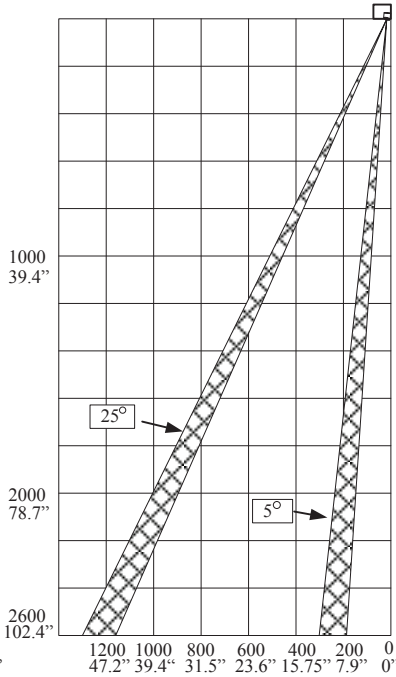

7. **Power On Check:** Before applying power to the unit(s) check all wiring again.



NOTICE: The Power On Check should be carried out with the Filter Cover off.

Place a test object in the desired detection area to verify the detection range, angle and Dip Switch settings are correct and make necessary adjustments. Once the Power On Check is complete, **turn power off** to replace Filter and Side Covers.

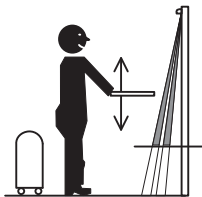

8. Replacing Filter Cover and End:

- A. First, fit the upper side of the Filter Cover along the full length of the Aluminum Case.

Slightly bend the Filter Cover at one end to latch it onto the bottom lip of the Aluminum Case.

Slightly bend the Filter Cover at one end to latch it onto the bottom lip of the Aluminum Case.

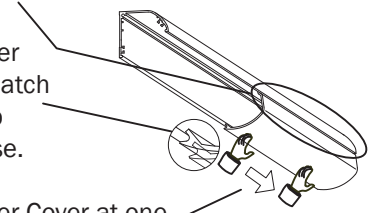

NOTICE: Insure wires do not block the lenses.

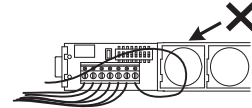

B. Attaching the Joint

- 1) Snap the Joint into the Aluminum Case.
- 2) Slide the Joint so that it fits snugly into the Filter Cover. Make sure there are no gaps left.
- 3) Attach remaining Filter Covers as illustrated.

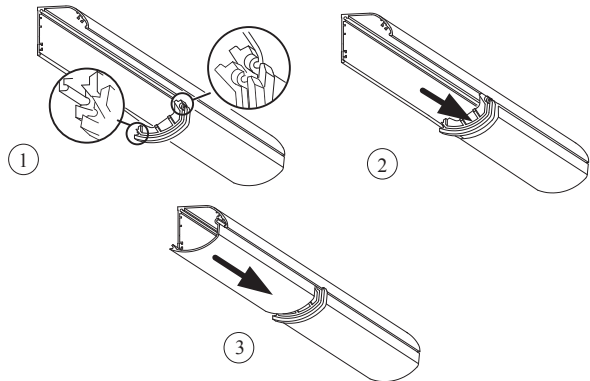

- C. Cut out the Side Cover's wiring point and insert the Wire Sheath into it.

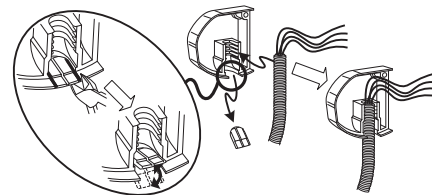

SSS-5

Door Mounted Presence Sensor

INSTALLATION INSTRUCTIONS

Section 5

Setup and Adjustment (continued)

D. Attach the Side Cover with Screws provided.

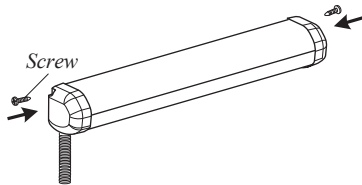

9. **Final Detection Range Test:** Apply power to the SSS-5(s) with the Filter Cover and End Caps properly installed. Confirm the unit(s) are functioning as expected.

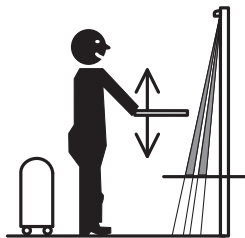

Section 6

Technical Data

Model.....	SSS-5 Door Mounted Presence Sensor
Detection Method.....	Active Infrared with Position Sensitive Detection (PSD) Measurement
Max. Installed Height.....	8'6" (2.6m)
Detection Range.....	0' to 8'6" (0 to 2.6m)
Range Adjustment.....	0'(0m) to 8'6"(2.6m)
Beam Angle Adjustment..	5°, 10°, 15°, 20°, 25°
Presence Timer.....	Infinity
Power Supply.....	12 to 24 V AC or DC ± 10%
Power Consumption.....	AC12V-1.7VA, AC24V-2.3VA (per sensor module) DC12V-95mA, DC24V-55mA
Output Contact.....	Form C Relay: DC50V 0.1A NonVoltage 1C
Test Input.....	6mA max. @ 24V DC
Response Time.....	<100mSec.
Delay Hold Time.....	0.5, 2 Sec.
Temperature Range.....	-4°F to 140°F (-20°C to 60°C)
Weight:	
SSS-5M1.....	1.2 lbs. (540g)
Color.....	Black

External Dimensions

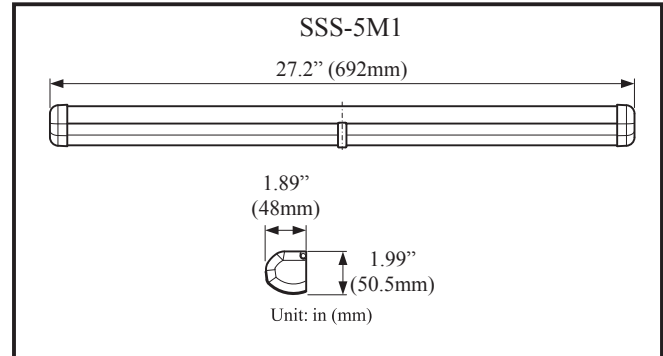

Section 7

Warranty

MS SEDCO guarantees this product to be free from manufacturing defects for 3 years from date of installation. Unless MS SEDCO is notified of the date of installation, the warranty will be in effect for 3 years from the date of shipment from our factory. If, during the first 3 years, our motion detector or support device fails to operate and has not been tampered with our abused, the unit can be returned prepaid to factory and it will be repaired free of charge. After 3 years, the unit will be repaired for a nominal service charge. **This limited warranty is in lieu of all other warranties expressed or implied, including any implied warranty of merchantability, and no representative or person is authorized to assume for MS SEDCO any other liability in connection with the sale of our products. All warranties are limited to the duration of this written warranty. In no event shall MS SEDCO be liable for any special, incidental, consequential or other damages arising from any claimed breach of warranty as to its products or services.**