

EAGLE ARTEK

Unidirectional opening sensor for automatic doors

(US version)



Visit website for available languages of this document.

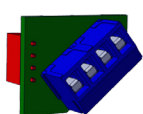
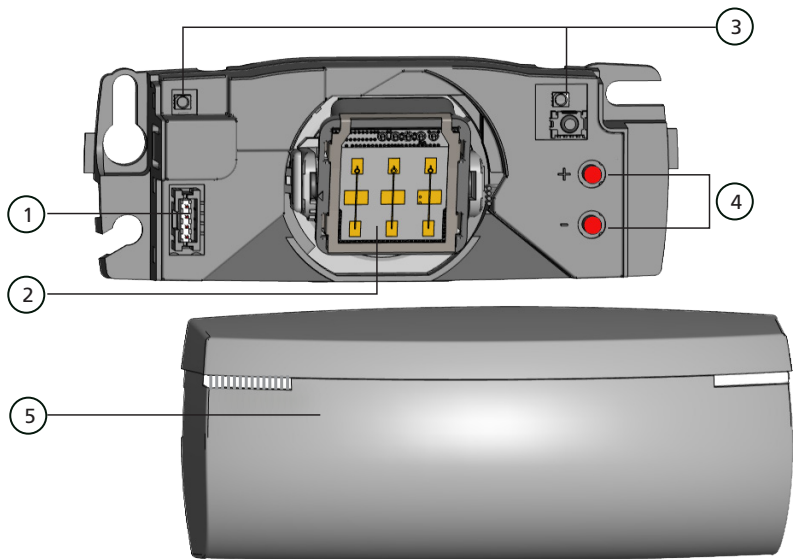

retrofit interface



harness (35.1563)

1. main connector
2. antenna
3. LEDs
4. push buttons
5. cover

ACCESSORIES

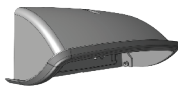

Rain accessory
10EARA



Ceiling accessories
10EACA (white)
10EACA-BLK (black)



Replacement covers
35.0303 - black
35.0319 - white
35.0320 - silver



Bracket accessory
10EABA

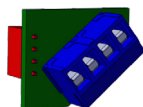

Retrofit interface
10EARETROFIT

BLANK PAGE

EAGLE ARTEK

Next Generation Motion Sensor For Automatic Sliding And Swing Doors



EAGLE ARTEK is equipped with BEA's DRO Radar technology that provides full digital adjustment of the radar field shape eliminating the need to swap antennas manually. Many hours of research, development and testing have been invested to create and develop the Artek technology. Thanks to the know-how of our engineers, this active digital antenna takes motion detection to the next level. The robust and sustainable design, cutting edge electronics and software allow for precision, reliability, and more flexibility.

Other benefits include:

- Robust & sustainable design
- Cutting edge electronics
- In-House production for better quality control and supply chain autonomy

Our goal is to provide you with user-friendly solutions. **EAGLE ARTEK** comes with the following *improvements*:

- Compact design - Allows discreet integration with all types of door control, even the slimmest ones
- Utilizing ARTEK technology developed by BEA and based on the EAGLE, this antenna inherits the stability and flexibility of our motion sensors
- Electronic management of the radar field shape and push-button adjustments for detection field allow for quick installation and setup
- Same mounting references and plug-in interface accessory make it easy to retrofit **EAGLE**

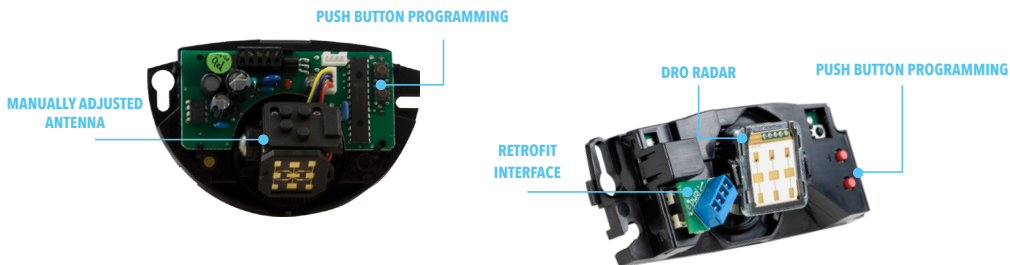

BLANK PAGE

TECHNOLOGY / PERFORMANCE

Technology	microwave
Detection mode	motion
Transmitter frequency:	24.15 GHz
Transmitter radiated power:	< 20 dBm EIRP
Transmitter power density:	< 5 mW/cm ²
Max. detection range:	wide: 13' × 6.5' narrow : 6.5' × 7' (@ 7' high)
Min. detection speed:	2 in/s

ELECTRICAL

Supply voltage*:	12 – 24 VAC ±10% (50 – 60 Hz) 12 – 24 VDC +30% / -10%
Max. power consumption:	< 1 W
Output*:	solid-state relay (free of polarity)
Max. switching voltage:	30 VAC / 42 VDC
Max. switching current:	100mA (resistive)

PHYSICAL

Mounting height:	6 – 13'
Tilt angles:	0 – 90° vertical -30 – 30° lateral
Temperature range:	-4 – 131 °F (-20 – 55 °C)
Dimensions:	4.72" (L) × 1.96" (H) × 1.96" (W)
Material:	ABS
Weight:	120 g
Cable length:	8'

COMPLIANCE

Degree of protection:	IP54 (IEC 60529)
FCC certification:	FCC: G9B-100606 IC: 4680A-100606

* External electrical sources must be within specified voltages, max 100 W, and ensure double insulation from primary voltages

*Specifications are subject to change without prior notice.
All values measured in specific conditions.*

MOUNTING OPTIONS

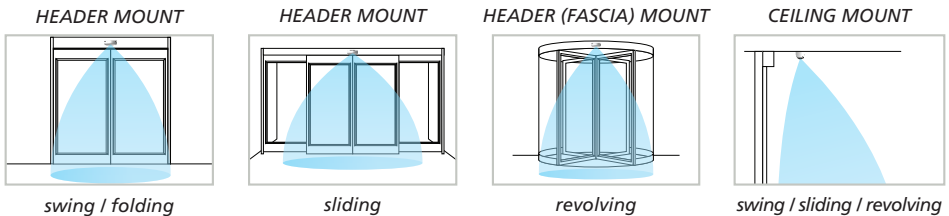

PRECAUTIONS



CAUTION

- ❑ Shut off all power going to header before attempting any wiring procedures.
- ❑ Maintain a clean and safe environment when working in public areas.
- ❑ Constantly be aware of pedestrian traffic around the door area.
- ❑ Always stop pedestrian traffic through the doorway when performing tests that may result in unexpected reactions by the door.
- ❑ *ESD (electrostatic discharge)*: Circuit boards are vulnerable to damage by electrostatic discharge. Before handling any board, ensure you dissipate your body's ESD charge.
- ❑ Always check placement of all wiring before powering up to ensure that moving door parts will not catch any wires and cause damage to equipment.
- ❑ Ensure compliance with all applicable safety standards (i.e. ANSI A156.10) upon completion of installation.
- ❑ DO NOT attempt any internal repair of the components. All repairs and/or component replacements must be performed by BEA, Inc. Unauthorized disassembly or repair:
 1. May jeopardize personal safety and may expose one to the risk of electrical shock.
 2. May adversely affect the safe and reliable performance of the product resulting in a voided warranty.

INSTALLATION TIPS

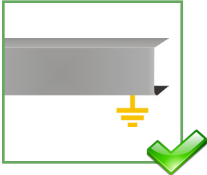

The door control system and the header cover profile must be correctly grounded.



Only trained and qualified personnel are recommended to install and set up the sensor.

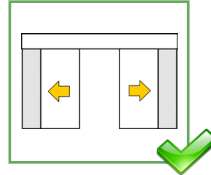

Always test the proper operation of the installation before leaving the premises.

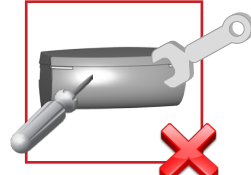

The warranty is invalid if unauthorized repairs are made or attempted by unauthorized personnel.



Avoid vibrations.

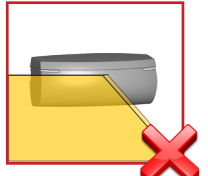

Do not cover the sensor.

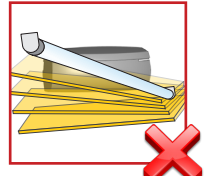

Avoid proximity to neon lamps or moving objects.

CLEANING & MAINTENANCE



Do not use harsh cleaning agents.

OPENING THE SENSOR

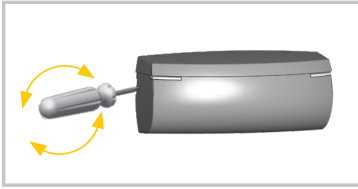

Insert the screwdriver on the left or right notch of the sensor and twist to remove the cover.

MOUNTING & WIRING

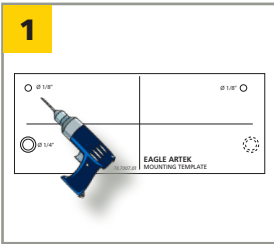

Using the mounting template, drill the cable pass-thru hole and 2 mounting holes.

Cable pass-thru: \varnothing 1/4"
Mounting holes: \varnothing 1/8"

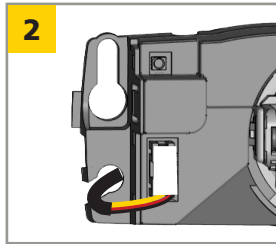

Pull the cable through the pass-thru hole, and plug in the connector accordingly.

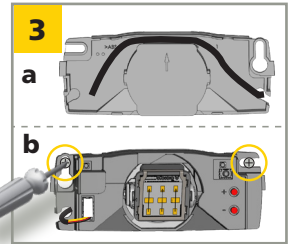

- Route the cable relative to the pass-thru hole. To avoid damage, use the dedicated cable path on the sensor base.
- Secure the sensor by hand-tightening the mounting screws.

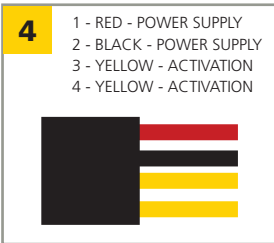

Wire to the door controller.
Logic selectable via remote control
(see following page)

RETROFITTING: OPTIONAL HARDWIRING

If you wish to utilize the existing cable from the door control, simply install the Retrofit Interface module (10EARETROFIT).

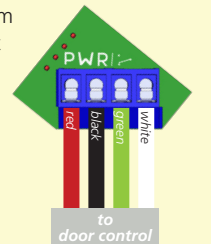
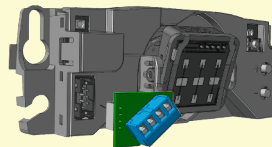

FIELD ANGLE ADJUSTMENTS

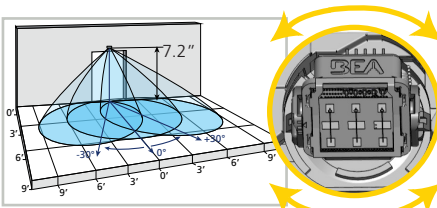

Adjust the lateral antenna angle.

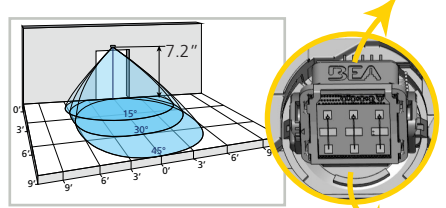

Adjust the vertical antenna angle.

SETTINGS

via REMOTE CONTROL

FACTORY VALUES:



		0	1	2	3	4	5	6	7	8	9
FIELD SIZE		XXS	XS	S	>	>	>	>	L	XL	XXL
FIELD SHAPE		<p> = wide (default) = narrow</p> <p>To query the specific width, press .</p> <p>The sensor will blink the number of times that it is set to, and then the green LED will blink either 1 time (narrow shape) or 2 times (wide shape).</p> <p>Example: If FIELD SIZE = large and FIELD SHAPE = narrow, the LED will blink 7 times, and then 1 time.</p>									
MOUNTING HEIGHT			< 10 ft	> 10 ft							
IMMUNITY FILTER			low	normal	high	>	>	>	>	>	highest
DETECTION MODE			bi	uni	uni MTF	uni AWAY	MTF & AWAY	bi = two-way detection uni = one-way detection towards sensor uni MTF = one-way detection with motion-tracking feature uni AWAY = one-way detection away from sensor			
OUTPUT CONFIG			NO	NC							
HOLD-OPEN TIME		0.5 s	1 s	2 s	3 s	4 s	5 s	6 s	7 s	8 s	9 s
DOOR CONTROL			auto	open	closed			open = sensor detects constantly, LED on closed = sensor is in standby and does not detect, LED off			
FACTORY RESET										full	partial *

* outputs are not reset

ACCESS CODE

The access code (1 to 4 digits) is recommended to set sensors installed close to each other.

Saving an access code:



Deleting a known access code:



Deleting an unknown access code:



Once you have saved an access code, you must always enter this code to unlock the sensor.

If you forget the access code, **cut and restore the power supply**. Within 1 minute, you can access the sensor without introducing any access code.

SETTINGS (cont.)

via PUSH BUTTONS

FIELD SIZE

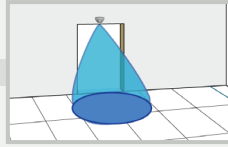
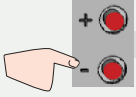

... S, XS, xxs

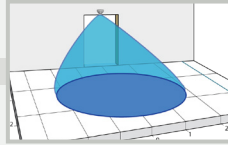
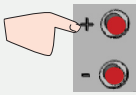

... L, XL, XXL

FIELD SHAPE

ENTER



long push (2 sec)

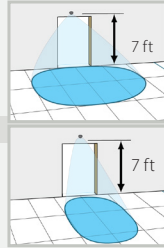
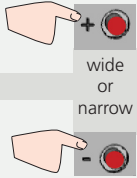

OK

X 1

EXIT



long push (2 sec)

IMMUNITY

ENTER

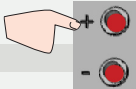

long push (2 sec)

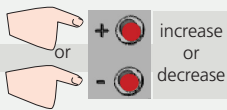

OK

X 1

EXIT

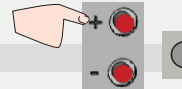





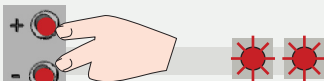

long push (2 sec)

FACTORY RESET – full reset only



long push (4 sec)

TROUBLESHOOTING

	Door remains closed, LED off	Sensor power is off	Check the wiring and the power supply.
		Door control (F2) is set to 3 (closed)	Change the door control setting (F2) to value 1 (automatic).
	Door does not react as expected	Incorrect output configuration on the sensor	Change the output configuration setting on each sensor that is connected to the door operator.
	Door does not react as expected	Wire to the antenna is disconnected or damaged	<ol style="list-style-type: none"> 1. Check wire to the antenna. 2. If damaged, replace sensor.
	Door opens and closes repeatedly	The sensor is disturbed by the door motion or vibrations caused by the door motion	<ol style="list-style-type: none"> 1. Ensure the sensor is secured. 2. Ensure the detection mode is unidirectional. 3. Increase antenna angle. 4. Increase immunity filter. 5. Reduce field size.
	Door opens for no apparent reason	Sensor detects rain	<ol style="list-style-type: none"> 1. Ensure detection mode is unidirectional. 2. Increase immunity filter.
		Sensor detects objects outside of its detection field (in highly reflective environment)	<ol style="list-style-type: none"> 1. Change antenna angle. 2. Decrease field size. 3. Increase immunity filter.
		Sensor detects movement of the opposite door (in an airlock vestibule)	<ol style="list-style-type: none"> 1. Change antenna angle. 2. Adjust field shape. 3. Increase immunity filter.
	LED flashes quickly after unlocking	Sensor requires access code to unlock	<ol style="list-style-type: none"> 1. Enter the correct access code. 2. If you forgot the code, cut and restore the power supply to access the sensor without access code. 3. Change or delete the access code.
	Sensor does not respond to remote control	Weak or incorrectly installed batteries	Check batteries and change if necessary.
Remote control not aimed at sensor		Point the remote control towards the sensor.	
	Door remains open, LED stays on	Door control is set to "open"	Set the door control to "auto" (see pg. 8).

BEA, INC. INSTALLATION/SERVICE COMPLIANCE EXPECTATIONS

BEA, Inc., the sensor manufacturer, cannot be held responsible for incorrect installations or incorrect adjustments of the sensor/device; therefore, BEA, Inc. does not guarantee any use of the sensor/device outside of its intended purpose.

BEA, Inc. strongly recommends that installation and service technicians be AAADM-certified for pedestrian doors, IDA-certified for doors/gates, and factory-trained for the type of door/gate system.

Installers and service personnel are responsible for executing a risk assessment following each installation/service performed, ensuring that the sensor/device system performance is compliant with local, national, and international regulations, codes, and standards.

Once installation or service work is complete, a safety inspection of the door/gate shall be performed per the door/gate manufacturer's recommendations and/or per AAADM/ANSI/DASMA guidelines (where applicable) for best industry practices. Safety inspections must be performed during each service call – examples of these safety inspections can be found on an AAADM safety information label (e.g. ANSI/DASMA 102, ANSI/DASMA 107, UL294, UL325, and International Building Code).

Verify that all appropriate industry signage, warning labels, and placards are in place.



A Halma company

Tech Support & Customer Service: 1-800-523-2462
General Tech Questions: techservices-us@BEAsensors.com | Tech Docs: www.BEAsensors.com

BLANK PAGE