

USERS GUIDE

MS-09 IP-65 (NEMA 4) MAGIC SWITCH

PRODUCT DESCRIPTION

The MS-09 (PN:10MS09TL, 10MS09L) is an IP-65 rated of BEA's MS-08, a touchless switch that operates on the Doppler effect principle. A microwave signal is emitted from the sensor. When this signal is reflected from a target, the signal is compared to the original signal. If the target is moving, the frequency of the reflected signal is different from the emitted signal. This difference in frequency is processed and sends a signal to the door to open. This switch provides excellent control of door operation for industrial doors by reducing energy costs. It also provides door control in sterile environments and has a sleek profile to limit dust collection. The MS-09 may be mounted behind various non-reflective materials such as plastic, wood, and glass. However, the thickness of any material put in front of the switch may affect the operation of the detector. Reflective materials such as metal will prevent the detector from working. The MS-09 has adjustments that allow the range of detection to be varied from 2 to 24" and relay hold time of the door to be varied from 1 to 10 seconds.

SAFETY PRECAUTIONS



- Shut off all power going to the header before attempting any wiring procedures.
- Maintain a clean & safe environment when working in public areas.
- Constantly be aware of pedestrian traffic around the door area.
- Always stop pedestrian traffic through the doorway when performing tests that may result in unexpected reactions by the door.
- Always check placement of all wiring before powering up to insure that moving door parts will not catch any wires and cause damage to equipment.
- Ensure compliance with all applicable safety standards (i.e. ANSI A156.10) upon completion of installation.

COMPONENT ID



10MS09TL



10MS09L

TECHNICAL SPECIFICATIONS

DESCRIPTION	SPECIFICATION
Technology	Microwave
Radiated Frequency	24.125 GHz
Radiated power density	5 mW/cm ²
Supply voltage	12 to 24VAC ± 10% 12 to 24VDC +30% / -10%
Main Frequency	50 to 60Hz
Power Consumption	< 2W
Output	Relay with switch-over contact (voltage free)
Relay contact rating (max voltage)	60 VDC/ 125 VAC
Relay contact rating (max current)	1A (resistive)
Max switching power	30W (DC)/ 60VA (AC)
Detection Range	2" to 24" (adjustable)
Output Hold Time	0.5 to 10 seconds (adjustable)
Temperature Range	-30°F to + 131°F
Immunity	Immune to electrical and radio frequency interference
Weight	0.34 lbs.

INSTALLATION

INSTALLATION

The MS-09 may be mounted to any surface and ½" conduit should be used to run wire to the sensor.

- Do not place the sensor in the door's opening range, where the sensor may see door movement.
- Do not place objects that could move in front of the sensor.

1. Wire a 4-conductor cable to the door operator according to manufacturer specifications.

Color	Description
White	Common
Green	N/O contact
Empty	N/C contact
Red	12 to 24VAC+10%
Black	12 to 24VDC+30% / -10%

2. Attach the 4-conductor cable connector to the Magic Switch.

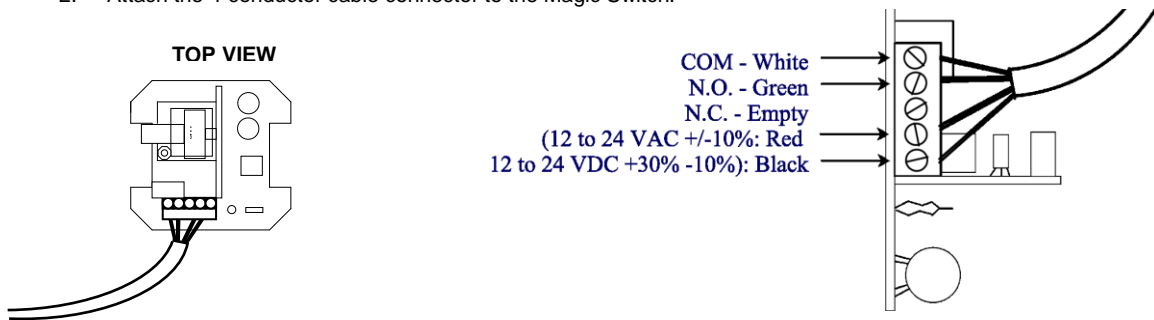

3. Adjust the unit to the desired set-up. First, carefully remove the protective nylon cap. Two adjustments can be made to the sensor by simply a simple turn of a potentiometer. The top potentiometer is used to adjust the size of units' sensing field and the bottom one adjusts the units' hold time.

SENSING FIELD

Rotate the top potentiometer clockwise to increase the size of the sensing field. It may be adjusted from 2" to 24".

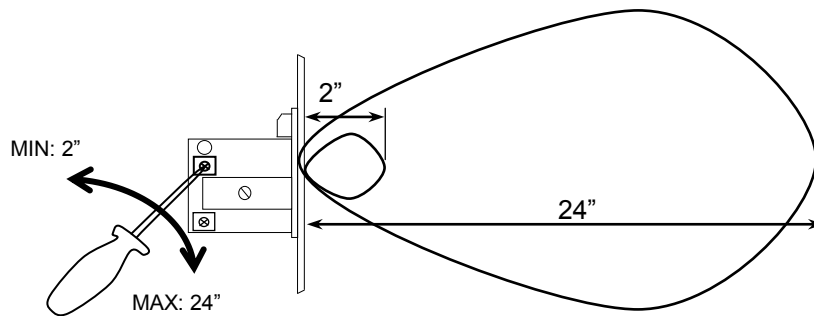

OUTPUT HOLD TIME

Rotate the bottom potentiometer clockwise to increase the time the output contact will stay energized. It may be adjusted from 0.5 to 10 seconds.

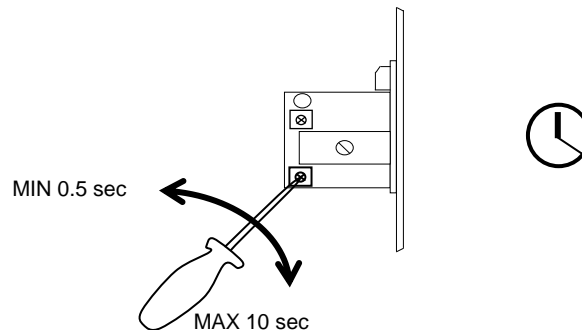

ASSEMBLY

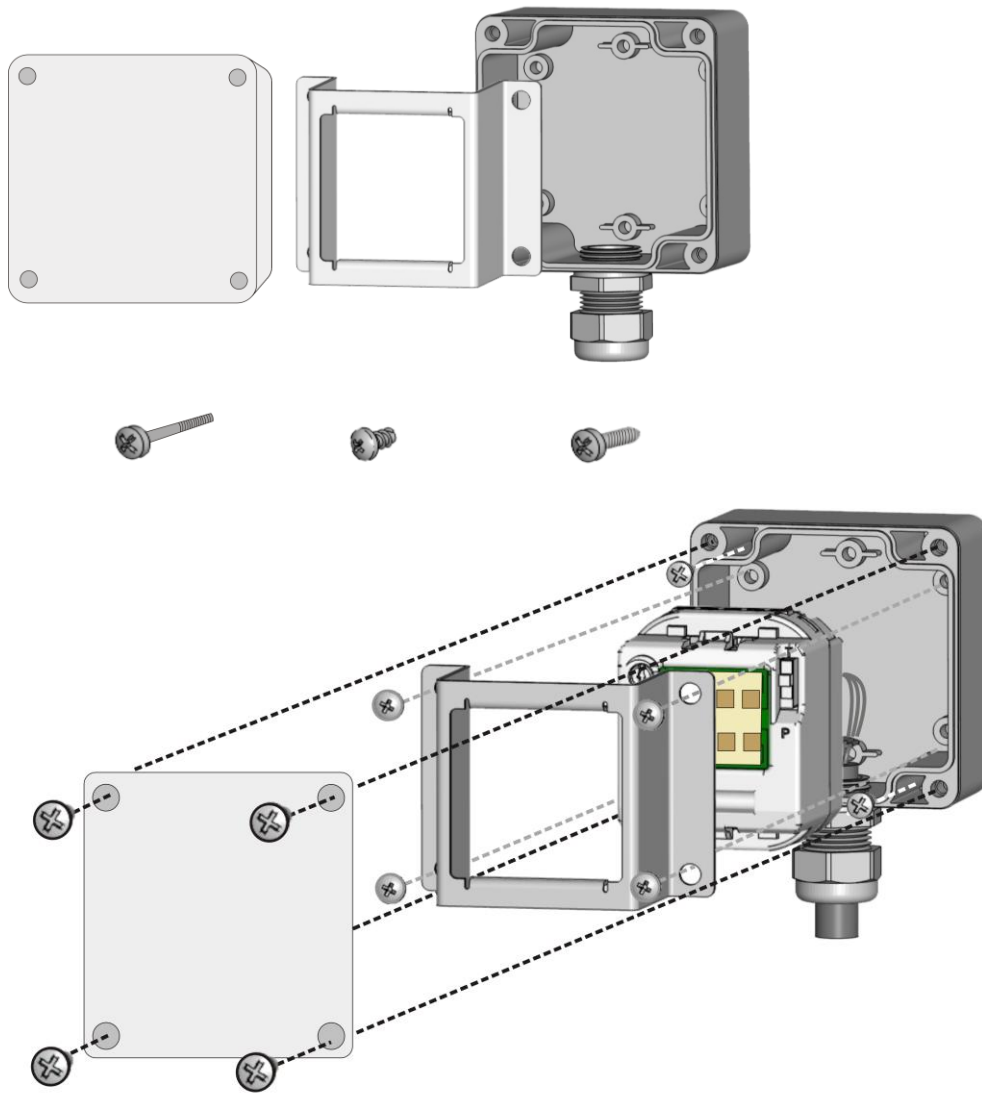

TROUBLE-SHOOTING

PROBLEM	CORRECTIVE ACTION
Door will not close	<ol style="list-style-type: none"> 1. Check the sensor connections 2. Check the range setting
Door remains permanently open	<ol style="list-style-type: none"> 1. Check the sensor connections 2. Check the hold time setting 3. Check the sensors fastening 4. Make sure there are no unintended moving objects in detection field

COMPANY CONTACT

If after troubleshooting a problem, a satisfactory solution cannot be achieved, please call B.E.A., Inc. for further assistance during **Eastern Standard Time at 1-800-523-2462 from 8am - 5pm**. For after-hours, call East Coast: 1-866-836-1863 or 1-800-407-4545 / Mid-West: 1-888-308-8843 / West Coast: 1-888-419-2564. **DO NOT leave any problem unresolved.** If you must wait for the following workday to call B.E.A., leave the door inoperable until satisfactory repairs can be made. **NEVER sacrifice the safe operation of the automatic door or gate for an incomplete solution.**
Web: www.beainc.com