

**ERICH INDUSTRIES, Inc.  
PERFORMANCE PRODUCTS DIVISION**

**MODEL 630 and 300 AUTOMATIC DOOR OPERATORS**

**INSTALLATION INSTRUCTIONS & OWNERS MANUAL**

**FOR FLUSH HUNG OR CENTER HUNG DOORS WITH UP TO 2 ½" REVEAL**

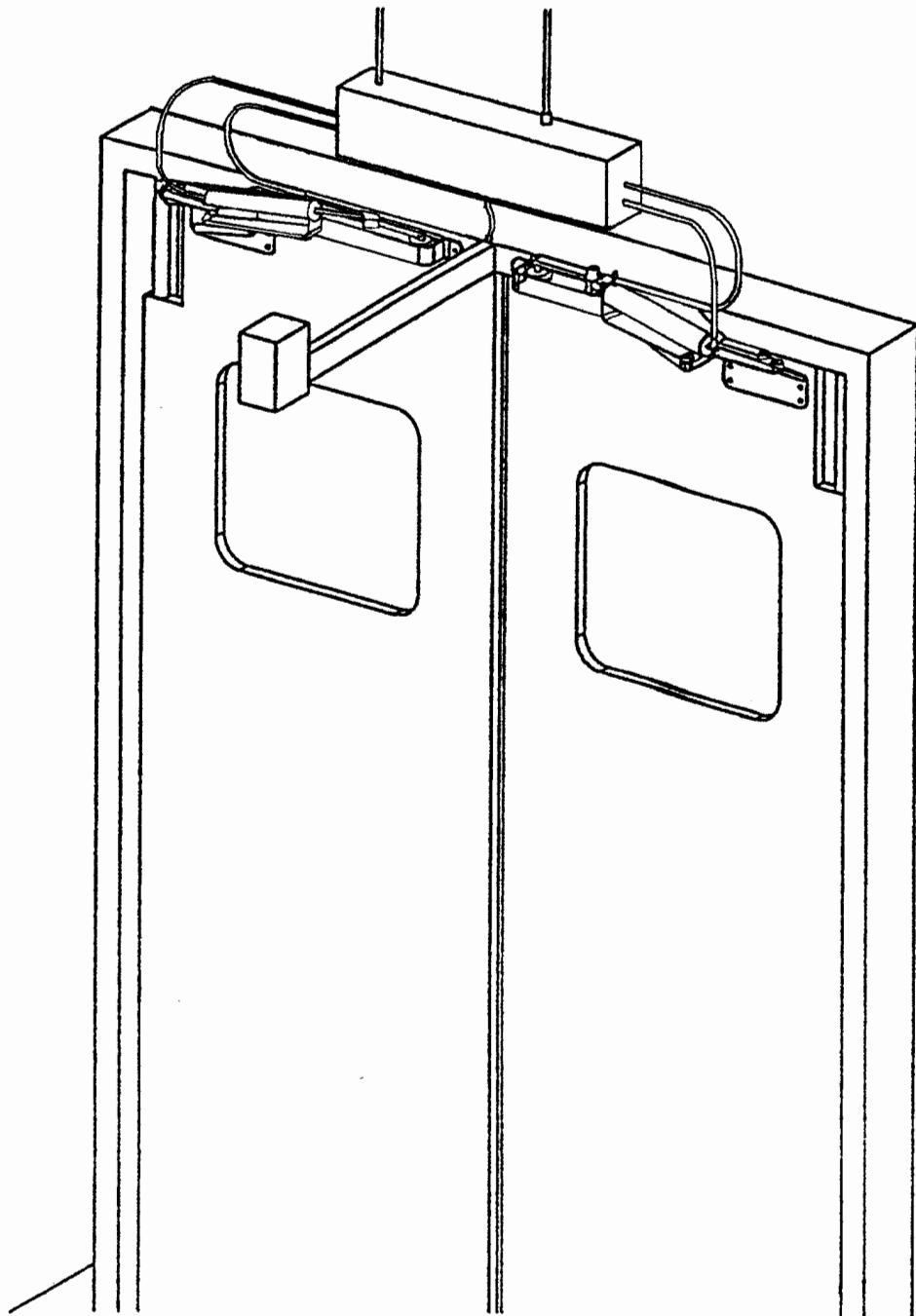

# CHASE INDUSTRIES' "KWIK-OP" PNEUMATIC DOOR OPENER

INCLUDES: (1) CONTROL BOX, (2) ACTUATORS, AND (2) ROLLER TRACKS COMPONENT, CONTROL BOX, AIR LINE PLUMBING AND ELECTRICAL WIRING LAYOUT

- (A) CONTROL BOX: SURFACE MOUNTED (CAN BE MOUNTED IN REMOTE LOCATION).
- (B) PNEUMATIC DOOR ACTUATOR (OPENER).
- (C) ROLLER TRACK with SHOCK ABSORBER
- (D) MOTION DETECTOR (OR OTHER ACTIVATOR).
- (E) AIR LINE FROM COMPRESSOR WITH 1/4" NPFT FITTING, HIDDEN OR SURFACE MOUNT - BY OTHERS.
- (F) 1/4" FLEX AIR LINE TO CONTROL BOX: HIDDEN OR SURFACE MOUNT.
- (G) 1/4" FLEX AIR LINE TO ACTUATOR(S): SURFACE MOUNT.
- (H) ELECTRICAL SOURCE: 110 VOLT / 60 CYCLE - BY OTHERS.
- (I) ELECTRICAL JUNCTION BOX W/DUPLEX OUTLET (OR AS REQUIRED BY LOCAL CODE) FLUSH OR SURFACE MOUNT - BY OTHERS.
- (J) 3 PRONG 110V PLUG CORD, PLUGGED INTO JUNCTION BOX (OR AS REQUIRED BY LOCAL CODE).
- (K) LOW VOLTAGE WIRING FROM ACTIVATOR(S) PLUGGED INTO CONTROL BOX.
- (L) ON / OFF SWITCH ( WHITE - OFF  
RED - ON )
- (M) HOLD OPEN SWITCH

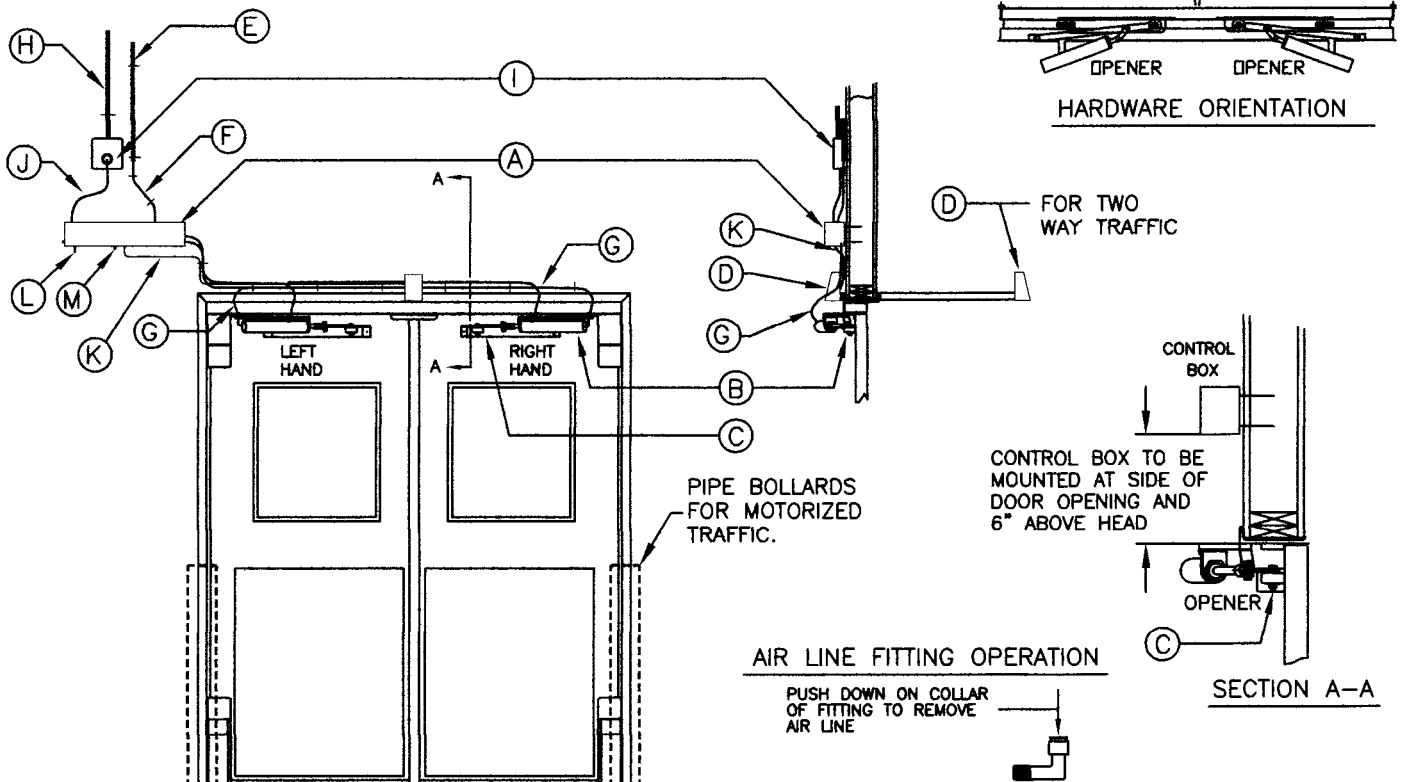

REV. 6/18/98  
REV. 12/22/94

ANY QUESTIONS? CALL DOOR DYNAMICS AT 1-800-305-6736

DWG. NO. DD-9010A

## Section 2 – Safety

### - WARNING -

Read these safety practices before installing, operating or servicing the door opener. Failure to follow these safety practices could result in property damage, serious bodily injury or death.

**READ AND UNDERSTAND ALL OPERATING INSTRUCTIONS IN THIS MANUAL BEFORE OPERATING THE DOOR OPENER.** If you do not understand the instructions, ask your qualified supervisor to teach you how to use the door opener.

**IMPORTANT:** Doors must have vision panels in each door panel and/or be in accordance with all applicable OSHA or other governing rules and regulations.

1. Do not operate the door opener while under the influence of drugs or alcohol.
2. Do not use the door opener if it or the door appears in any way to be broken or not operating properly. Advise your supervisor at once.
3. Stay clear of the door and door opener while moving.
4. Keep all body parts including hands, feet, and head clear of door and door opener at all times.
5. Do not operate the door opener with equipment, material, people or any other object in the door or openers operational path.
6. Disconnect power before performing any electrical, mechanical or air supply service, cleaning or other maintenance on the door or door opener. OSHA requires power and air supply to be properly tagged and locked out during all maintenance or service of the equipment. With the power supply disconnected, always verify using a volt meter.
7. All electrical, mechanical or air supply troubleshooting or service must be completed by a qualified personnel or service person and must meet all applicable local, state, federal, international and any other governing agency codes.
8. When it is necessary to service the control box with power on, **USE EXTREME CAUTION.** Do not place any fingers or un-insulated tools inside the control box. Touching wires or other parts inside the enclosure may cause electrical shock, serious injury or death.
9. It is your responsibility to keep all warning labels and instructional manuals legible, intact and kept with the door opener. Replacement labels and manuals are available from Erich Industries, Inc.
10. Prior to putting the door opener into operation the user must have a safety training meeting with all personnel and users to instruct them on proper operation and all applicable safety procedures.
11. If you have any questions contact your supervisor or Erich Industries, Inc.
12. Failure to operate the door opener as intended, as described, or heed any warning may result in equipment damage, property damage, serious bodily injury or even death.

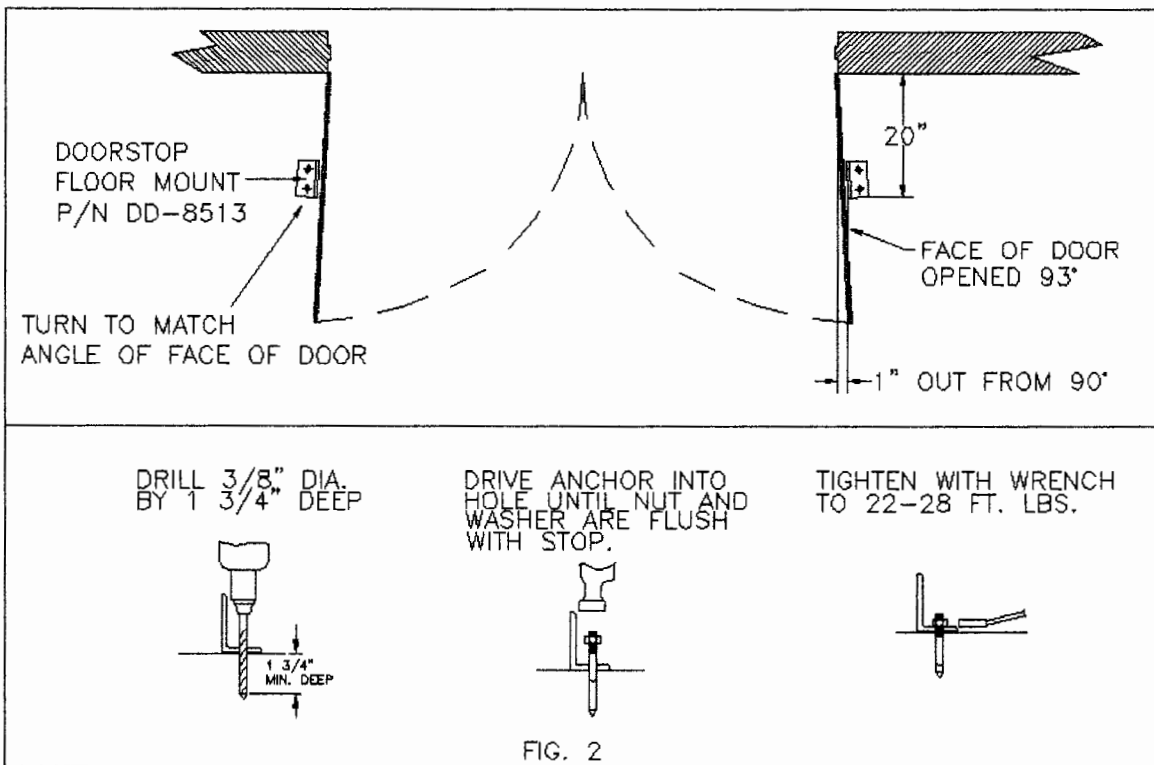

**Step 5.** Install opener/closer door bracket and backer plate, drill (4) 5/16" diameter holes using bracket DD-7015 as a template. After door bracket has been attached to the door, attach the actuator assembly to the door bracket. All mounting/installation hardware is included (P/N # DD-8510), see Fig. 3 for assembly details.

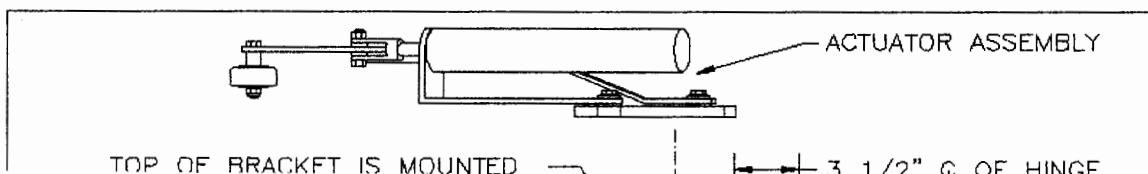

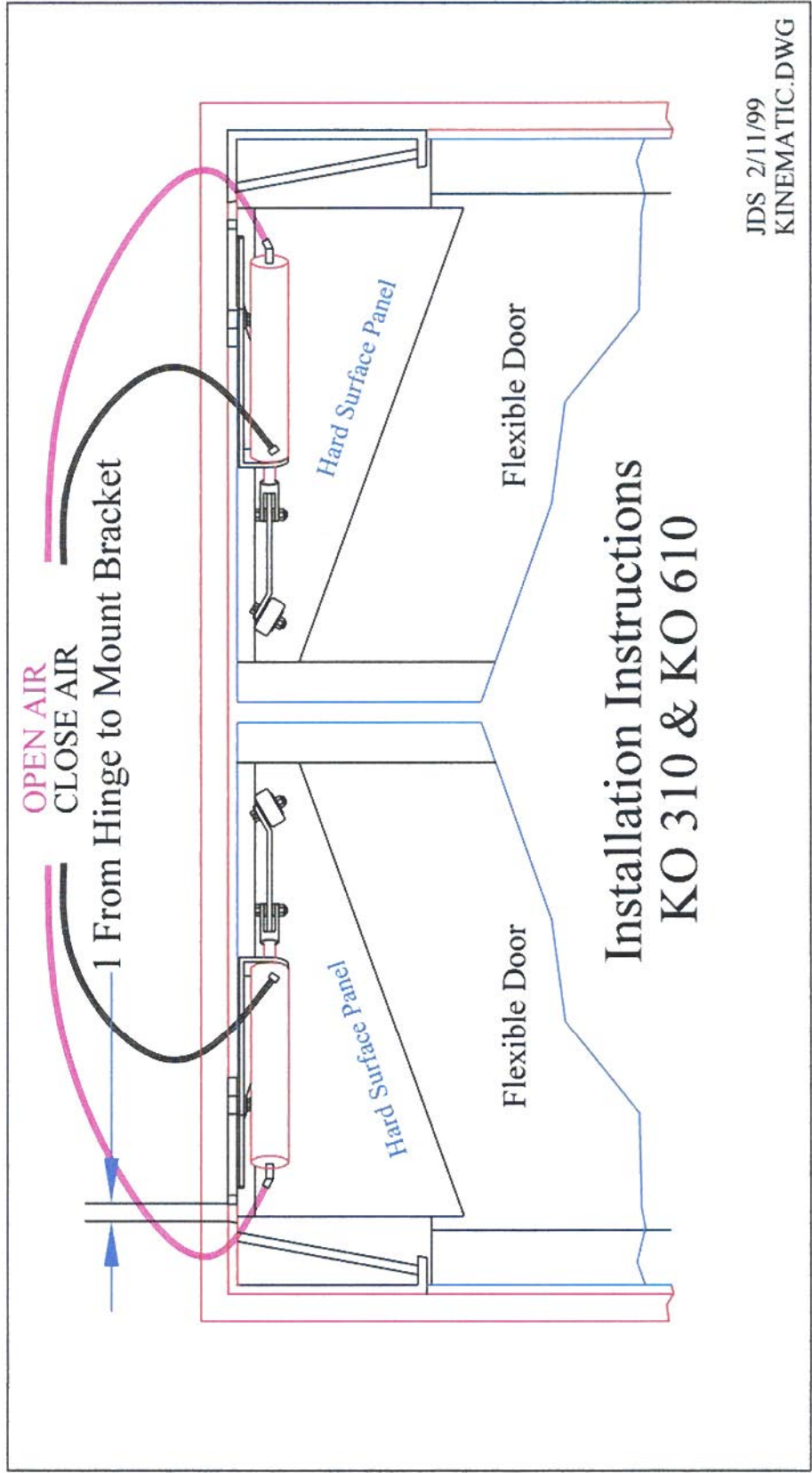

**Step 5.** Install opener/closer actuator, drill (4) 5/16" diameter holes using bracket 15043 as a template. See Figure 3 for drilling locations. All mounting/installation hardware is included (P/N # B8111), see Fig. 3 for assembly details.

### Header Mount Installation Procedure

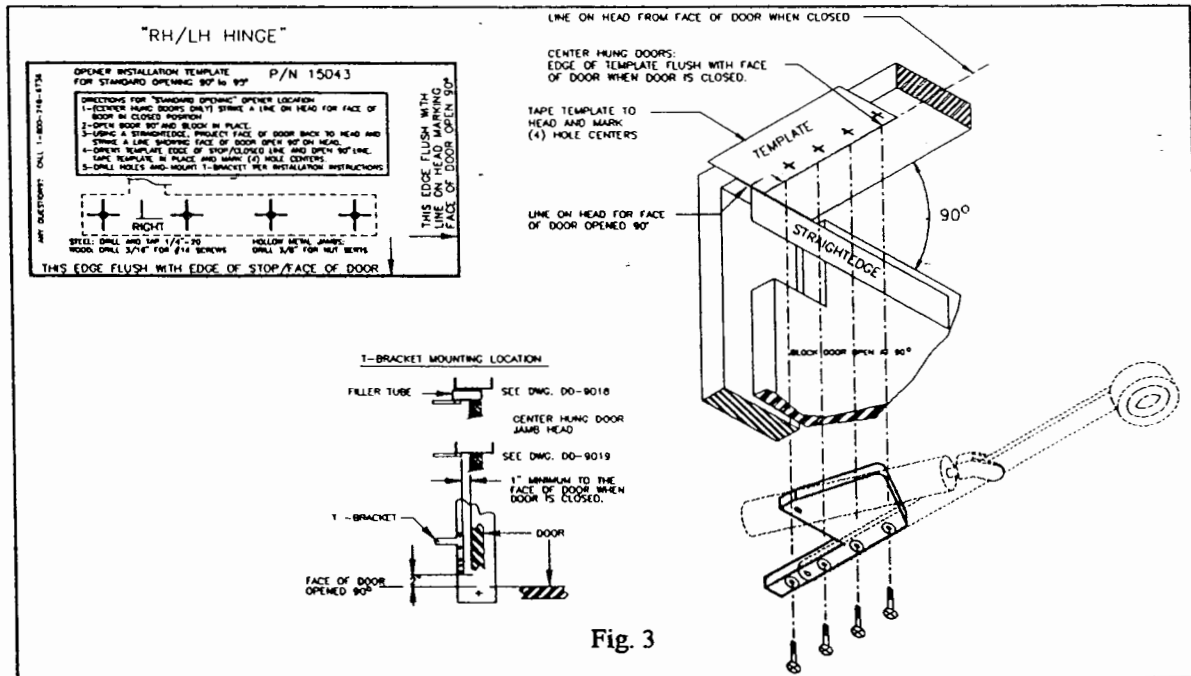

**Step 8.** Install the activating device (motion sensor, pull switch, etc.) according to manufacturers instructions. If an optional extension bracket is used for mounting a sensor please refer to Fig. 5 for instructions on positioning and mounting.

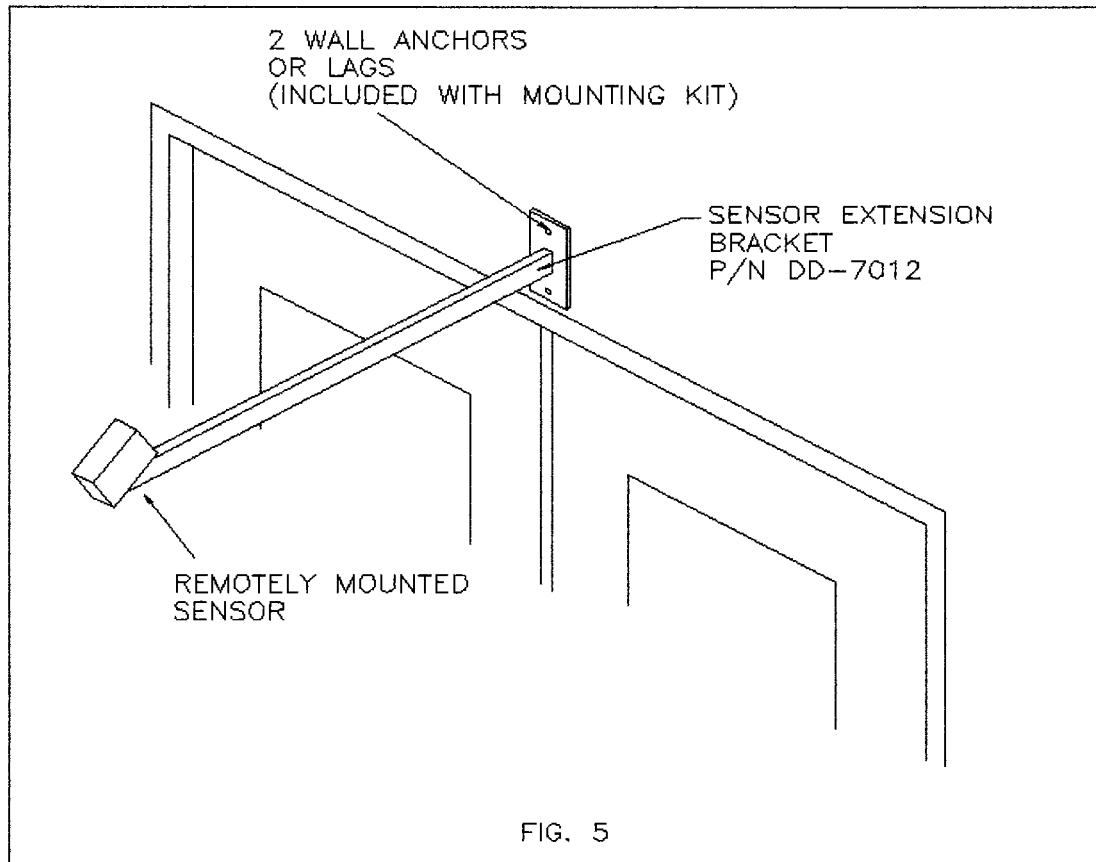

**Step 9.** Install air lines from control box to actuators, all ports are labeled for open or close. Use tees provided if required to split air lines as needed.

**Step 10.** Connect control box to air and electric supply. Make sure that control box power switch is turned off before connecting power to the box.

*CAUTION!! The door will move to the closed position as soon as air is connected to the control box, even if the power is turned off or not yet connected.*

**Erich Industries, Inc.**  
**AIR FORCE® AND DOOR DYNAMICS® DOOR OPENER**  
**ELECTRICAL WIRING DETAILS**

Our control box is microprocessor based to insure maximum reliability and flexibility for the user. The system has been designed to be easy to set up and operate. Directions for setting the proper program are in the Circuit Board User's Manual located elsewhere in this manual. The control unit is designed to be connected to a constant power source of 110VAC 60HZ or 230VAC 50HZ, which powers the control box and a wide variety of activation devices with 24VAC power.

Activating devices and input signals should be connected directly to the terminal strip located on the left side of the control board.

- N = Power Common Lead
- N = Power Common Lead
- U = Unused - Auxiliary
- R = Remote Proof of Closure Signal
- S = Safety Signal (Sensors)
- I = Initiate Signal
- #1 = Unused - Auxiliary
- #2 = Unused - Auxiliary
- E = Safety Signal (Lockout)
- D = Safety Signal (Photoeyes)
- F = Fire Signal
- P = Proof of Closure Switch Signal
- H = 24V Power
- H = 24V Power

Notes: Use Terminal strip connection to N and F to lock out opening if maglock is used and active. We recommend Asterix model 176 maglocks and a separate power source. Door will remain in open position if receiving input from terminal strip D or S regardless of input from activation device.

Below we provide wiring details for a variety of activation and safety devices available from Erich Industries. In most cases other manufacturer's models can also be wired to the system in a similar fashion. Please consult with the manufacturer of that particular unit with questions or call us.

**E-2005 MS Sedco microStar Motion Detector**

- Red to H
- White to N
- Brown to I
- Black to N

**E-3090 MS Sedco DH400 Presence Sensor**

- Red to H
- Black to N
- Yellow to E
- White to N

**E-3060 MS Sedco GD11S Photoeye Safety Beam**

- Transmitter: White to H
- Black to N
- Receiver: White to H
- Black to N
- Gray to D
- Green to N

**E-5010 MS Sedco 216 Touchless Switch**

- Red to H
- Green to N
- Red to N
- Blue to I

**E-3070 BEA Microcell Photoeye Safety Beam**

- #1 to H
- #2 to N
- #3 to D
- #4 to N

**E-5020 BEA MS-08 Touchless Switch**

- Red to H
- Black to N
- White to N
- Green to I



**E-4020 MS Sedco 99 Push Plate**

Normally Open to I  
Common to N

**MS Sedco 614 Piezo Switch**

Normally Open to I  
Common to N

**BEA IS40 and IS40P Sensors**

Red to H  
Black to N  
White to N  
Green to I  
White/Black to N  
Green/Black to E (for safety with lockout)

**E-5040 BEA MS09 Touchless Switch**

Red to H  
Black to N  
White to N  
Green to I

**E-5060 Piezo Push Button Switch**

Plus to H  
Minus to N  
Com1 to N  
Normally Open to I

**E-6010 VEE CP1 Pull Cord**

Normally Open to I  
Common to N

**MS Sedco DH94 Presence Sensor**

Red to H  
Black to N  
Yellow to E  
White to N

**E-5030 BEA MS21 Touchless Switch**

Red to H  
Black to N  
Green to I  
White to N  
Green/yellow to Earth Ground

**E-5050 BEA MS11 Touchless Switch**

Red to H  
Black to N  
Green to I  
White to N

**E-1010-1EX Explosion Proof Push Button**

Normally Open to I  
Common to N

Additional questions can typically be answered by calling the factory technical support staff at 1-800-882-5839.

Revision 01/01/23

# Chase Industries Kwik Op Circuit Board User's Manual

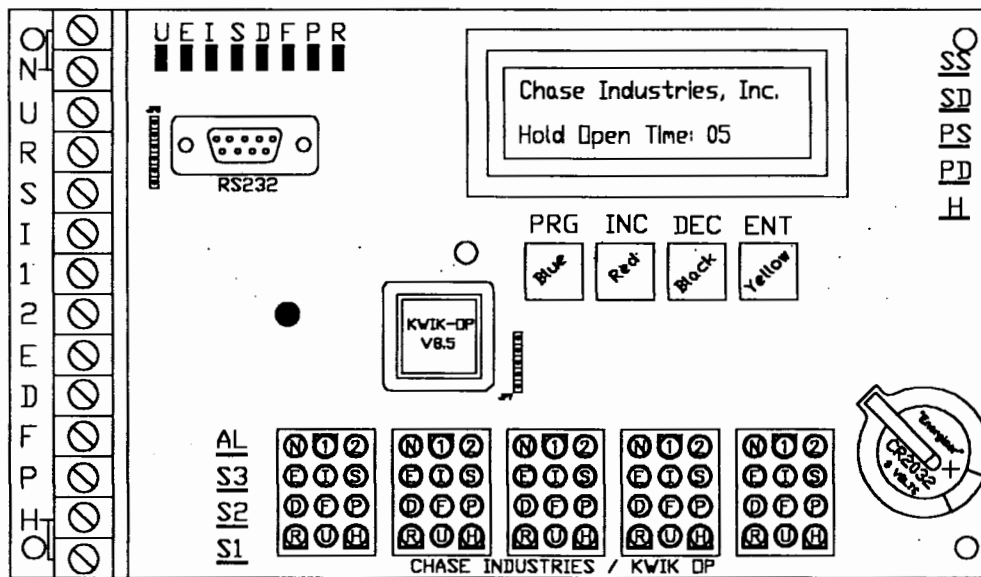

# Chase Industries Kwik-Op Door Control

## Control Board Software User's Manual

### General

#### Status/Health LED

A single red LED displays the general health of the controller. These indications are summarized in the following table:

Indication	Meaning
1 short blink every second	Controller is running normally
1-7 blinks every 6.4 seconds	Error condition
LED off	Controller failure
LED on for 5 seconds then off	Internal failure; clock failure or firmware corruption

In the case of errors, the number of times the LED blinks within each 6.4 second indicates which error(s) have been detected. The number of blinks is the sum of the failure counts in the table below:

Error	Blink Code
LCD Controller Failure	1
Non-volatile storage read/write failure	2
Non-volatile storage checksum error	4

The number of blinks in error mode indicates the *sum* of these blink codes, e.g. a combined non-volatile storage R/W failure with data corruption will result in a blink count of 6 each 6.4 seconds.

#### LCD Controller Failure

This error is indicated when proper communications cannot be established with the liquid crystal display module's controller. The error is cleared at power-up. If this indication persists, it indicates that the LCD module probably needs to be replaced.

#### Non-volatile Storage Read/Write Failure

This error indicates that the non-volatile storage contained in the real-time clock is unreliable. The error is cleared at power-up and is tested during each initialization.

#### Non-volatile Storage Checksum Failure

This error is an indication that the non-volatile parameter storage was corrupt when it was loaded at power-up. This is a normal indication when the control is first powered up prior to being programmed. This condition is cleared when any operation is performed that writes the non-volatile parameters, such as pressing the **PRG** button while in Local Programming Mode.

# Programming

Setting the functional parameters in the control can be accomplished by either using the operator keyswitches on the control marked **PRG**, **INC**, **DEC** and **ENT** or by connecting a serial terminal to the control. Using the keyswitches is referred to as “Local Programming” while using a serial device is referred to as “Remote Programming”. Only one programming method can be in use at a given time.

## Parameters

### Local Programming

When the controller is not any programming mode, pressing the **PRG** key on the board will place the control into Local Programming Mode and Remote Programming Mode is inhibited.

While in Local Programming Mode, the keys on the control perform the following functions:

<b>PRG</b>	Advances to the next value to be displayed or changed. This key auto-repeats.
<b>INC</b>	Increments the current value of the displayed parameter. Values “wrap around” from maximum value to minimum values. This key auto-repeats.
<b>DEC</b>	Decrements the current value of the displayed parameter. Values “wrap around” from minimum value to maximum values. This key auto-repeats.
<b>ENT</b>	Pressing this key causes any changes made to be stored in non-volatile storage so that they will be loaded when the control is next powered up. Note that if this key is <i>not</i> pressed, any changes in values will not be stored and will be temporary. <sup>1</sup>

### Remote Programming

Remote programming of the unit is accomplished by connecting a standard DA-9P to DB-25 (or DB-9) “straight through” serial cable to the DA-9S onboard connector.<sup>2</sup> Only the transmit and receive data lines are required for operation in addition to a ground. The connected serial device must be set to 9600 baud, 8-bit data and no parity. For best results, the serial device should emulate an ANSI terminal and should have “destructive backspace” enabled and “local echo” off.

---

<sup>1</sup> It is not possible to make “temporary” changes to the time or date. Pressing **ENT** programs the clock, exiting programming mode without saving data doesn't.

<sup>2</sup> The actual serial connector and RS-232C electrical interface are optional. Remote serial programming can still be accomplished by providing a stand-alone TTL to RS-232C interface and converting the serial signals presented to the serial option connector instead.

## Standard Menu

Remote Programming mode is initiated by sending a single Carriage Return character. The controller will respond with the remote menu<sup>3</sup>:

CHASE INDUSTRIES KWIK-OP

- A) HOLD OPEN TIME
- B) VALID SAFETY
- C) TIME TO CLOSE
- D) DELAY TO SECOND
- E) MAGNETIC STRIKE
- F) OPERATION MODE
- G) COUNT TO PURGE
- H) PURGE LENGTH
- I) SET DATE
- J) SET TIME
- K) ZONE START
- L) ZONE END
- M) ZONE ACTIVE DAYS
- N) LANGUAGE

Enter Your Choice : \_

To select an item, enter the letter indicated (do not press **ENTER** ) and you will be prompted with the current value and, if applicable, the range of acceptable values, such as:

Enter Your Choice: **D**  
DELAY TO SECOND= 05 SECONDS, RANGE: 00-99, NEW VALUE=\_

If no value is entered, or if the entry is invalid, the existing value will not be changed. If no keys are pressed for 30 seconds, the controller will automatically exit the Remote Programming Mode. While in Remote Programming Mode, the on-board programming switches are disabled and the controller's LCD will show the message "REMOTE PROGRAM MODE ACTIVE".

In addition to the visible menu choices (A-N), additional special codes may be entered at this menu:

- \ Toggle debug mode
- ? Display Status
- S Special Factory Menu

## Debug Mode

While in Debug Mode, the controller's LCD will show the state of the various AC control output lines:

```
ALS3S2S1SSSDPSPD  
- - * * - - - -
```

A "-" symbol indicates that the related output is off, a "\*" indicates it is on.

## Status Display

The status display shows some internal settings and then reprompts the main menu.

---

<sup>3</sup> The menu text shown is for the default language (English).

## **Special Factory Menu**

The Special Factory Menu is:

FACTORY SPECIAL MENU

- A) CLEAR COUNTER
- B) SET COUNTER

Enter Your Choice : \_

These command clear and set the activation cycle counter.

## ***Special Modes***

### **Factory Defaults**

To return all parameters to factory default values, press and hold the **INC** and **DEC** switches when the control is powered up. The LCD will display a message requiring confirmation to restore defaults; pressing **ENT** confirms.

### **“Flip-Flop” Mode**

The “Flip-Flop” mode is intended for functional checkout of the control. It is activated by pressing the **PRG** switch when the control is powered up. Press the **ENT** switch to confirm activating Flip-Flop mode. Once activated, this mode continues until the control is powered down.

## Operation Mode Abbreviations

LCD Screen Display	Description
<b>STD TOG TIME-OUT</b>	Standard Toggle Mode Time-Out – door open when requested and doors close when requested. However, if the request to close is not received within the set amount of time (“Time To Close”) – the doors will close automatically.
<b>STD TOGGLE MODE</b>	Standard Toggle Mode – doors open when requested and doors close when requested – no timer function.
<b>STD TIMER MODE</b>	Standard Timer Mode – <b>Normal setting</b> , doors open when requested and close automatically after the “Time To Close” input time has been reached.
<b>TERMINA TIME-OUT</b>	Terminate Time-Out (Cancels Time Out Mode)
<b>INT TIMER MODE</b>	Interlock Timer Mode - Standard Interlock Timer Mode, doors open when requested and close automatically after the “Time To Close” input time has been reached.
<b>INT TOGGLE MODE</b>	Interlock Toggle Mode, first set of doors opens when requested, and doors close when requested - then, the second set of doors open. When requested the second set of doors close – no timer function.

Operation Mode is obtained by pressing the Program “PRG” (Blue Button) six times until “Operation Mode” is seen on the LCD Screen.

Using the Increase “INC” (Red Button) or Decrease “DEC” (Black Button) press until the Mode required is observed on the Screen.

After selecting the Mode press Enter “ENT” (Yellow Button) to store the Mode into memory.

**Note:** this setting is maintained even if the power is loss. If Enter is not pressed, the Mode selected will be temporary and will not be stored into memory.

**Interlock** – definition – first sets of doors must be closed before the second set of doors can open.

## Door Speed Control

Please refer to Fig. 6 for general control box layout

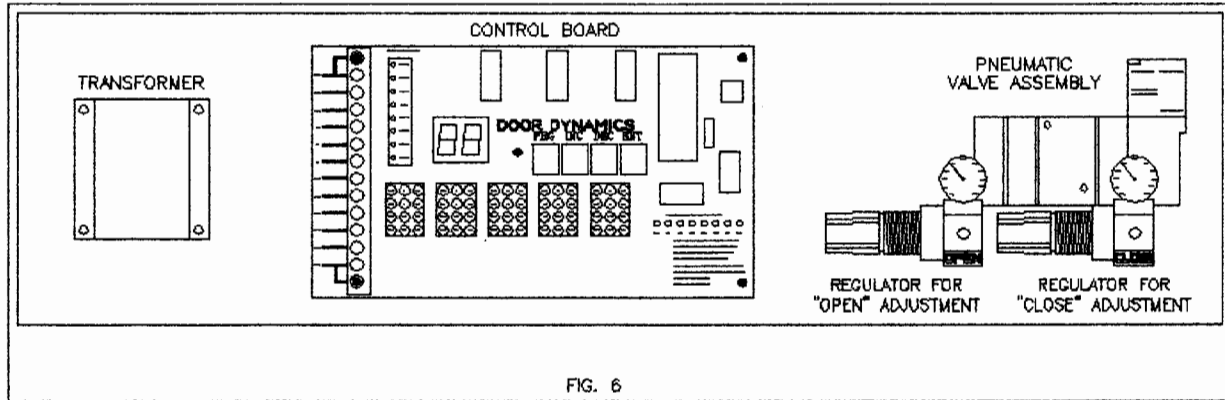

The door speed pressure settings have been factory preset to 35 PSI for the closing cycle and 40 PSI for the opening cycle.

- A. First check the opening speed at the factory setting of 40 PSI. If the opening speed is too slow increase the opening pressure by adjusting the open regulator. (It will be necessary to first pull the knob out to unlock the regulator.) Lowering the pressure will slow the door down. Make adjustments as needed. **Be aware, the door may slam open at this time, cushion adjustments will be made at a later time.** Lock the regulator by pushing the knob back in.
- B. Use the same procedure as above for adjusting the closing speed, using the close regulator.
- C. The opening/closing cylinder on the opener/closer is equipped with a flow control knob at each end. Adjusting the knobs will help slow the door down at the nearly fully open, and nearly fully closed position.

### **\* PLEASE NOTE \***

**USE THE OPPOSITE FLOW CONTROL KNOB TO MAKE ADJUSTMENTS FOR OPEN AND CLOSE CUSHION. EXAMPLE: THE DOOR IS SLAMMING OPEN: ADJUST THE FLOW CONTROL KNOB ON THE END OF THE CYLINDER LABELED CLOSE ON THE DOOR YOU ARE ADJUSTING. TURNING THE KNOB IN (CLOCKWISE) WILL ADD MORE CUSHIONING EFFECT TO THE OPENING CYCLE.**

**THE SAME IS TRUE FOR THE CLOSING CYCLE. ADJUST THE FLOW CONTROL KNOB LABELED OPEN ON DOOR YOU ARE ADJUSTING. TURNING THE KNOB IN (CLOCKWISE) WILL ADD MORE CUSHIONING EFFECT TO THE CLOSING CYCLE.**

**MAKE THE REQUIRED ADJUSTMENTS TO BOTH DOORS. THE FLOW CONTROL VALVES ARE EQUIPPED WITH THUMB WHEELS TO LOCK YOUR ADJUSTMENTS IN PLACE.**

**NOTE: THE DOOR SPEED MAY HAVE TO BE READJUSTED AFTER THE FLOW CONTROL CUSHIONS HAVE BEEN SET.**



---

## Section 4 - Operation

---

### Erich Industries

Performance Products Division Phone 800/305-6736

550 N. Nine Mound Road  
Verona, WI 53593

### OPERATING PROCEDURES FOR OPENERS

- A) **Start-up (refer to installation instructions for details)**
1. Make sure air lines have been purged (blown free of particles in air line) prior to supply line hook-up to control enclosure. Attach supply line to control enclosure.
  2. Plug in cord or hard wire to electric (110 volt) sources in accordance with local codes.
  3. Depress ON-OFF switch to turn on.
  4. Set activating devices to owner's requirements.
  5. Adjust opening speed with air pressure control knob in control enclosure. Never lower more than 40 PSI or raise higher than 85 PSI.
  6. Door should not slam open or closed. If this occurs, increase the back check on the door closer to a cushioned stop at the end of the cycle. Adjust the latch check on the closer for a cushioned close at the end of the closing cycle.
- B) **Operation**
1. Depress ON-OFF switch to activate door operator and turn on.
  2. Release ON-OFF switch to de-activate door operator and turn off.
  3. All activating devices must be plugged into control enclosure to function.
  4. Operators will not be damaged if held in closed or open position while activated for an extended period of time.
- C) **Emergency Operation**
1. In case of a power outage or if turned off, the doors will open and close manually. The operator will not be damaged when operated manually.
  2. Always turn operators off during a power outage and turn on when power is restored.
- D) **Shutdown**
1. Use ON-OFF switch on the control enclosure to de-activate the operator. Turn off.
-

### Erich Industries

Performance Products Division Phone 800/305-6736

550 N. Nine Mound Road  
Verona, WI 53593

### MAINTENANCE PROCEDURES FOR “KWIK-OP”

#### A) Maintenance - Air Source (as applicable)

1. Service compressors, filters, etc. as per manufacturer’s instructions.
2. Service should be carried out in 3 month intervals, or as required. Consult this manual for details.

#### B) Maintenance - Operators

1. Manually open doors to check for “*free swing*”. Adjust and/or lubricate hinges.
  2. Check actuator arms for excessive play. If required, loosen set screw or lock nut and tighten bolt to remove play. Do not over tighten, which will cause binding. After tightening set screw or lock nut, check again to insure that the unit has free action.
  3. Check cylinder jamb nut and tighten (if required) with the cylinder vent on the bottom.
  4. Lubricate bearing points with spray lube.
  5. Check air filter on supply air line. Clean, drain, or replace as required.
  6. Check, air hoses and connections for leaks, kinks, or contact with moving parts. Correct as required.
  7. Check air pressure and opening speed. Adjust per instructions as required.
  8. Check closer back check, closing speed, and latch speed. Adjust per instructions as required.
  9. Check Time Delay period. Adjust per instructions as required.
  10. Service should be carried out in 3 month intervals along with compressor servicing, or as required.
-

## MODEL 630 and 300 TROUBLE SHOOTING

### TROUBLE SHOOTING

#### 1. UNIT WILL NOT ACTUATE

- a. Check for physical jamming or binding of door.
- b. See if door will open using the hold-open switch on the control box. If it does work, go to (c) of these instructions, (problem is with input devices or control circuit board).
- c. Door does not open when using hold-open switch mounted on control box: problem is either with air supply or power supply. Open control box, and read gauge pressure, if open/close pressure is at least 30/20 PSI, the air supply is okay. If any lights are lit on control circuit board, problem may be a bad solenoid. If circuit board lights are all off, the problem may be loss of electrical power. Make sure the electrical outlet feeding the control box is working. If so, the problem may be a bad transformer.
- d. Door opens when using hold open switch, but does not respond to other open signals. Remove cover from control box observe the display on the control circuit board. It should be lit. If it is not, replace the control unit board.
- e. Observe the status lights in the upper left corner of the control circuit board. The second light from the left should light when any initiate signal is active (such as sensing motion detector). If this light does not indicate activity, the problem is most likely due to faulty or improperly wired sensor device.

If the status light does indicate activity when an object moves in front of the approach sensor, the problem may be a bad control circuit board.

#### 2. DOOR OPENS BUT WILL NOT CLOSE

- a. Check for binding of actuator arm and cylinder. Check for free movement of the door.
- b. Position of Safety Zone Sensor may cause it to "see" the door.
- c. Program function may be incorrect. (Refer to programming instructions in this manual.)

#### 3. UNIT ACTUATES, OPENS DOOR CORRECTLY, DOOR CLOSSES SLOWLY BUT NOT COMPLETELY.

- a. Check for free movement of door. Increase door closer air pressure if required (also adjust corresponding flow control for a soft closing). See installation instructions Speed Control page in this manual.
- b. Check for free movement of actuator arm and cylinder.

#### 4. DOOR ACTION TOO FAST, UNABLE TO CONTROL

- a. Reduce open air pressure to slow opening speed and reset flow control for soft open see installation instructions Speed Control page in this manual.

## "KWIK-OP" COMPONENTS

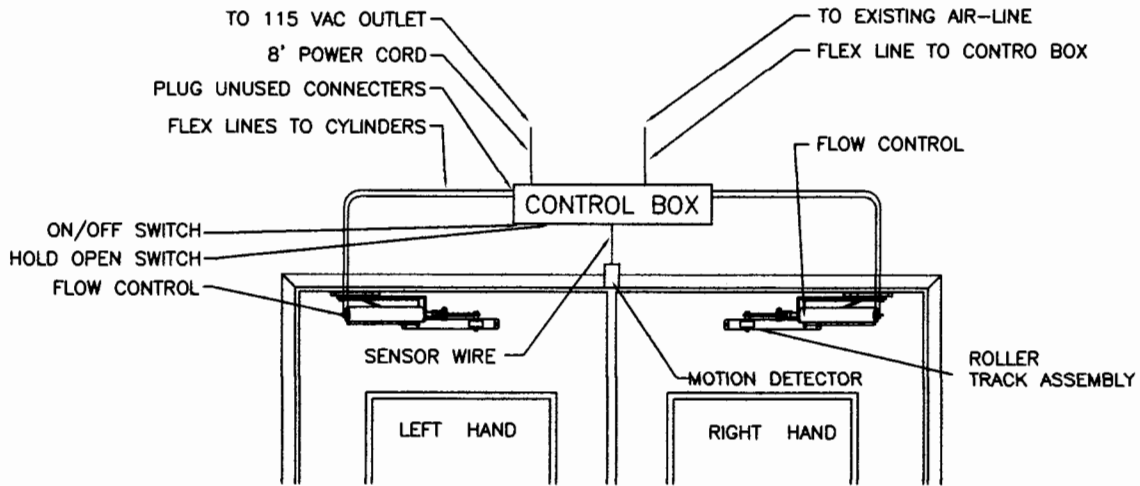

## "KWIK-OP" 630 ACTUATOR EXPLODED VIEW

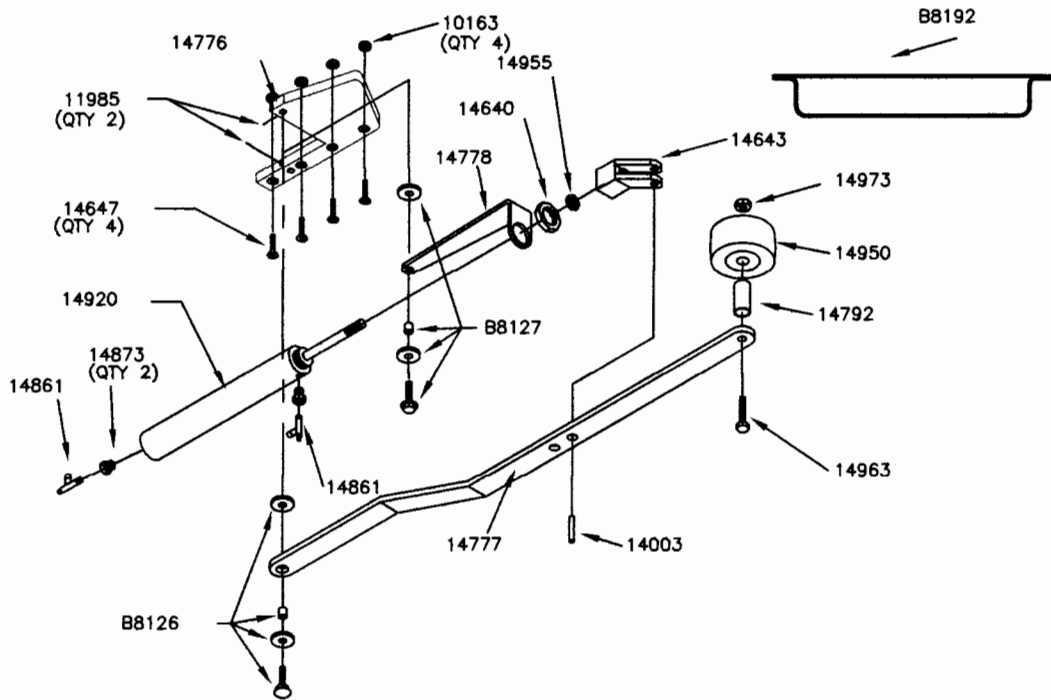

### PARTS LIST

Opener Parts	
14950 Wheel	14873 Reducer Bushing 14 NPT X 1/8 NPT(QTY 2)
11985 1/4"-20 Set Screw (QTY 2)	14643 Clevis
14963 5/16"-24 x 2 1/2" Hex Head Bolt	14778 Cylinder Bracket
14955 Jamb Nut, 1/2 - 20	14792 Shim Sleeve for Wheel
14003 Roll Pin, 5/16 Zink or S.S.	14627 Backer Plate
14647 1/4"-20 x 1" Flat Head Phillips (QTY 4)	14640 Hex Nut, 1 1/4 - 12, Zink, low profile
10163 1/4"-20 Nylock Nut (QTY 4)	B8126 Arm Pivot Bolt Assembly
14973 5/16-24 Nylock Nut	B8127 Cylinder Pivot Bolt Assembly
14920 Cylinder 2"x 8" Diameter	
14861 Swivel Flow Control	<b>Opener Assemblies</b>
14776 T-Bracket, Right Hand	B8192 Roller Track Assembly
14776 T-Bracket Left hand	B8224 Left Hand Opener, Complete Assembly
14777 Actuator Arm	B8225 Right Hand Opener, Complete Assembly
	B8101 Control Box (NOT SHOWN)