

# LZR<sup>®</sup>-WIDESCAN

OPENING, PRESENCE & SAFETY SENSOR  
FOR INDUSTRIAL DOORS

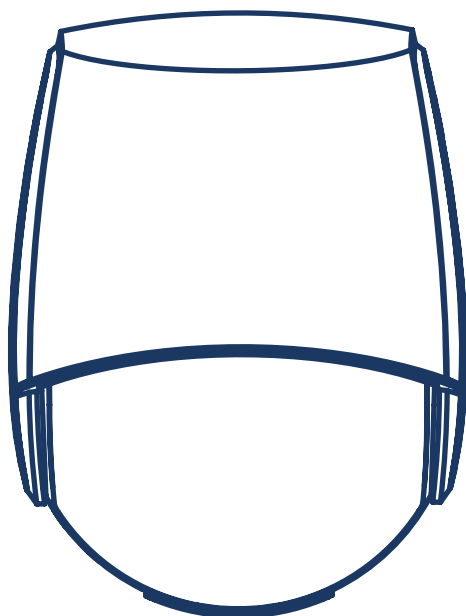

Visit website for  
available languages of  
this document.

A **Halma** company



## DESCRIPTION

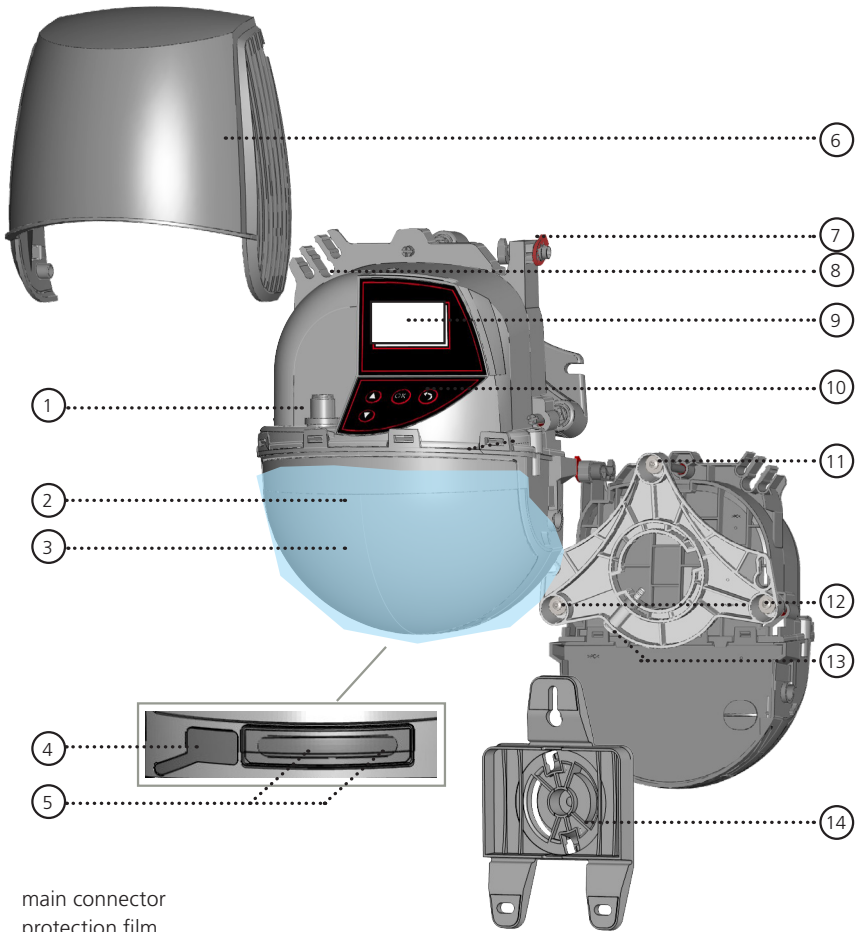

- |                    |   |
|--------------------|---|
| 1. main connector  | 9. LCD screen                           |
| 2. protection film | 10. keypad                              |
| 3. laser window    | 11. tilt angle adjustment screw (1)     |
| 4. USB cap         | 12. parallel angle adjustment screw (2) |
| 5. LED display     | 13. lateral angle lock screw (1)        |
| 6. cover           | 14. mounting bracket                    |
| 7. cover lock      |   |
| 8. cable passage   |   |

## USER'S GUIDE SYMBOLS

 Factory value (User's Guide)

 Factory value (LCD)

 Important!

 Good to know

## INSTALLATION & MAINTENANCE TIPS



Avoid extreme vibrations.

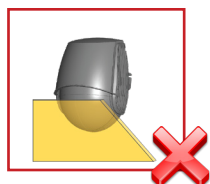

Do not cover the sensor.



Avoid moving objects and light sources in the detection field.

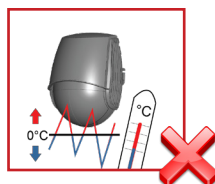

Avoid exposure to sudden and extreme temperature changes.

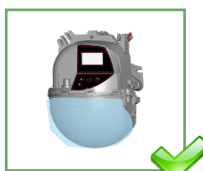

Keep the protection film during the mounting of the sensor. Remove it before launching a teach-in.

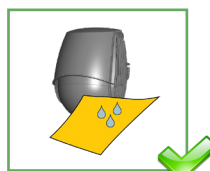

It is recommended to clean the optical parts at least once a year or more if required due to environmental conditions.



Do not use aggressive products to clean the optical parts.



Avoid direct exposure to high-pressure cleaning.

## SAFETY



The device emits invisible (IR) and visible laser radiations that can be activated during the installation process to adjust precisely the position of the detection field.

The visible laser beams are inactive during normal functioning.

**Do not stare into visible laser beams.**



### CAUTION!

Use of controls, adjustments, or performance of procedures other than those specified herein may result in hazardous radiation exposure.



Do not look directly into the laser emitter or the visible red laser beams.

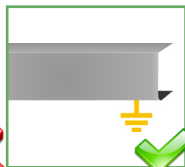

The door control unit and the header cover profile must be correctly grounded.



Only trained and qualified personnel are recommended to install and set up the sensor.

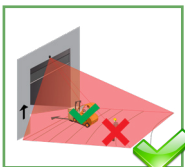

Following installation, always test for proper operation before leaving the premises.

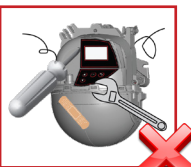



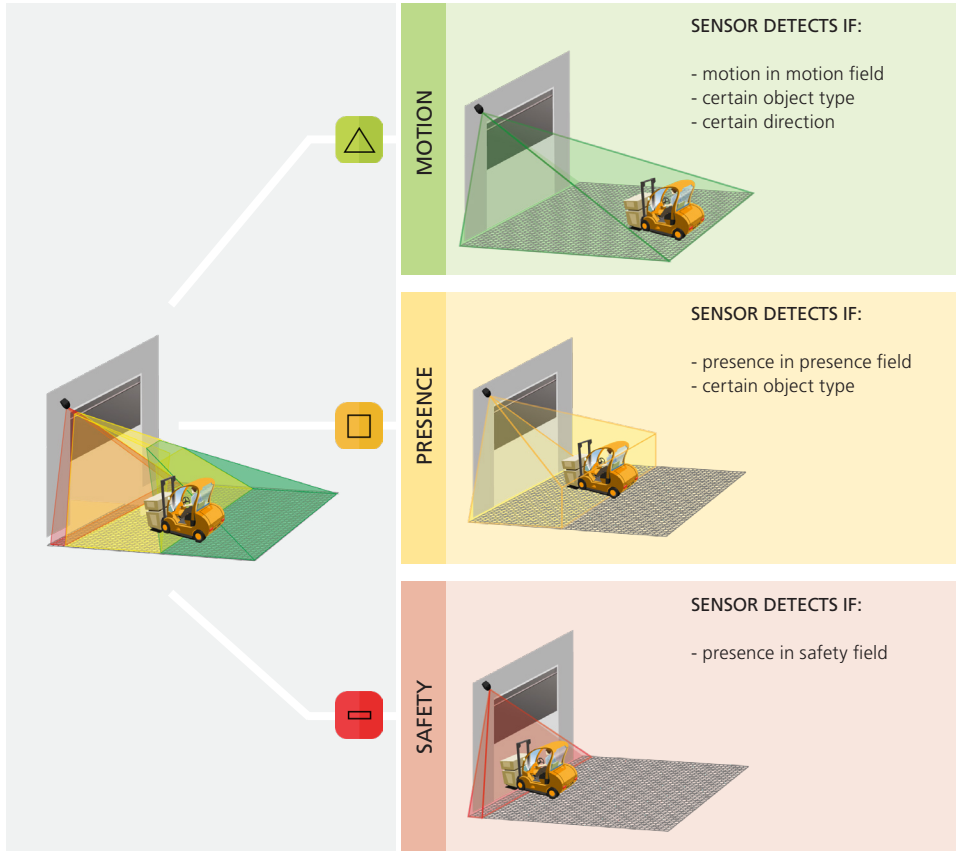

The warranty is invalid if unauthorized repairs are made or attempted by unauthorized personnel.

## BASIC PRINCIPLES: FUNCTIONS & OBJECT

There are 3 main functions that create **3 overlapping detection fields**, each with certain detection characteristics:



There are 4 additional opening functions. All detection functions can be combined to trigger a specific output.

-  **Motion +:** detection of other moving object type in motion field
-  **Pull-cord:** detection of object in learned, pull-cord zone
-  **Speed:** detection of object with a minimum speed
-  **Height:** detection of object with a minimum height

The sensor carries out a 3D object analysis and detects depending on height, width, depth, direction, and speed.

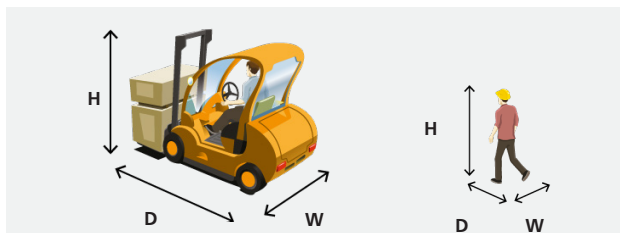

## 1 OPENING THE SENSOR

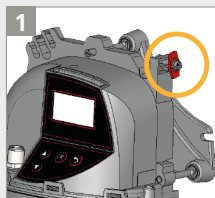

Before opening the sensor, make sure the cover is **not locked** (red cover lock).

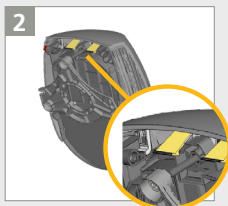

Pull the two legs on top in order to open the cover.

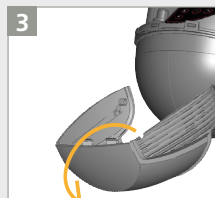

Remove the cover completely before installing the sensor.

## 2 MOUNTING



Mounting height: **as high as possible (max. 32')**.

Field width and field stop are limited by the mounting height (1:1.2). Sensor will adjust field sizes to the max possible value for the mounting height.

Mounting position: **center of door or left corner.**

Mounting on the right side of the door should be avoided.

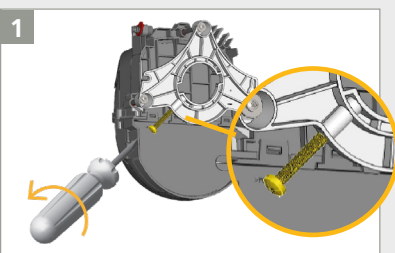
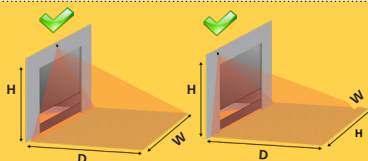

Verify that the angle lock screw is positioned as indicated. Unscrew slightly if necessary.

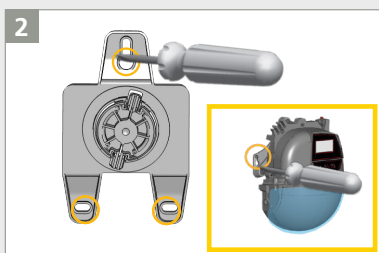

Remove the mounting bracket from the sensor and secure it to the wall. You can also install the sensor directly without using the mounting bracket.

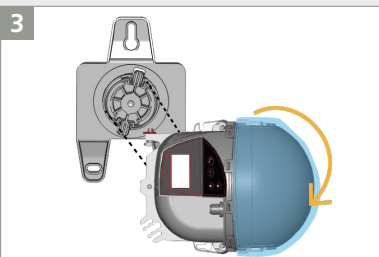

Position the sensor horizontally (as shown) and secure the sensor to the mounting bracket.

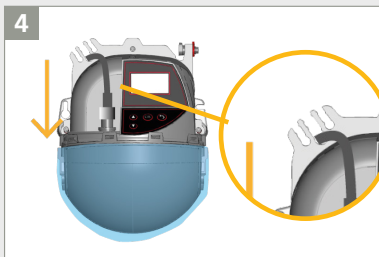

Plug in the connector and pass the cable (PN 35.1554) through the cable passage without making a loop.

### 3 POSITIONING OF DETECTION FIELD

Depending on the mounting location, position the detection field:

- **center mount:** adjust parallel and tilt angles (lateral angle adjustment may not be necessary)
- **off-center mount:** adjust parallel, tilt, and lateral angles

Remove the blue protection film from the laser window.

The two visible laser spots can be activated by pressing the OK button twice or pressing UNLOCK > MAGIC WAND > MAGIC WAND on the remote control.

PARALLEL ANGLE

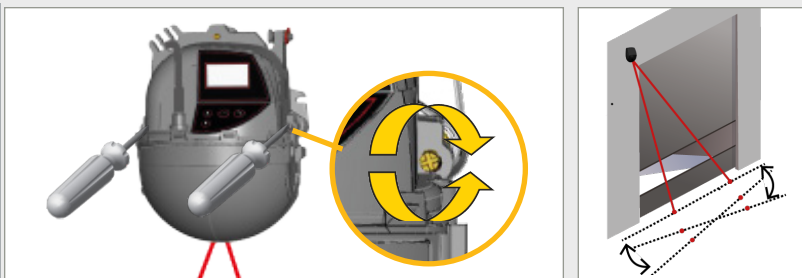

Make sure the curtain is parallel to the door by adjusting one or both screws on the side.

TILT ANGLE

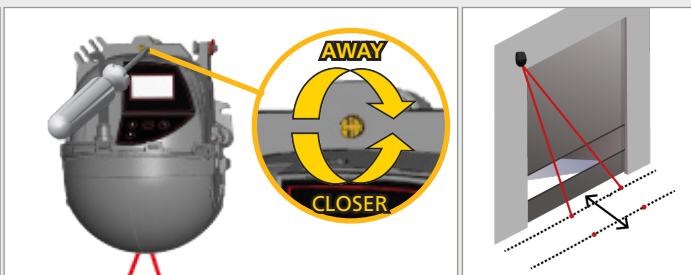

When the safety function is required, the red spots should be as close to the door as possible.

Negative angles reduce the depth of the detection fields.

Position the curtain closer to or farther away from the door by turning the screw at the top.

LATERAL ANGLE

Launch the POSITION WIZARD to position the detection field correctly in front of the door.

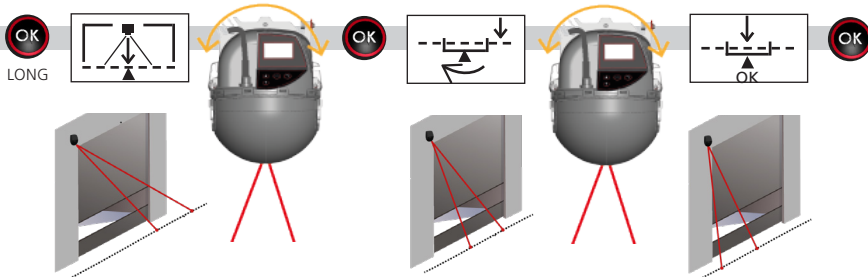

1. Push and hold OK to launch the POSITION WIZARD.
2. Rotate the sensor in order to align the center of the red spots with the center of the door. Push OK.
3. Rotate the sensor until the LCD screen validates the position. Push OK to exit.

**NOTE:** It is best to make minor adjustments to the sensor and then verify that you are not obstructing the pattern. Verify that both red spots are on the floor with no interference.

## 4 WIRING

Connect the wires accordingly. The output functions can be configured if necessary (see page 9).

See Appendix (page 17) for old harness wiring diagrams.

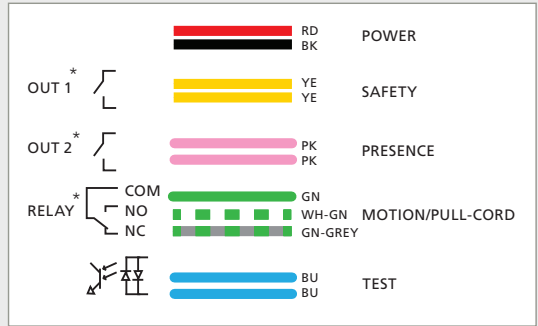

\*output status powered during non-detection with factory values

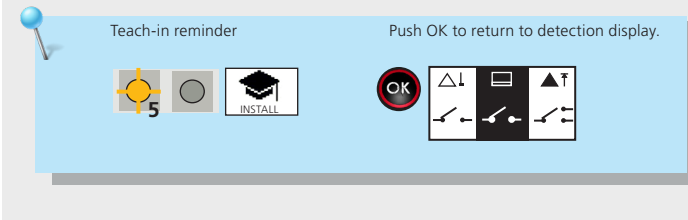

## 5 PROGRAMMING THE SENSOR

### LED SIGNALS & SYMBOLS



LED on



LED off



LED flashing



LED flashing quickly



LED flashing slowly



LED flashing x times

#### GENERAL

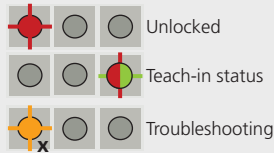

#### DETECTION

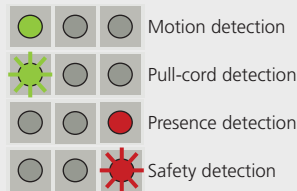

#### SMARTPHONE

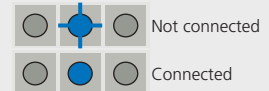

#### SETTINGS

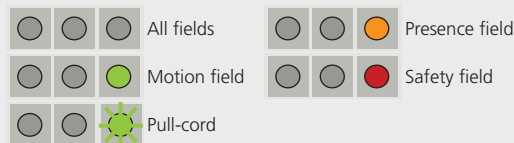

Setting any field width or depth to 000 will eliminate that field along with its associated LED flash.

## 4 PROGRAMMING THE SENSOR (cont.)

### a. TEACH-IN: INSTALL



- The teach-in zone (i.e. square in front of the 2 visible spots) must be completely clear.
- This teach-in must be launched each time a sensor angle has been changed.
- Make sure the blue protection film and cover are removed!

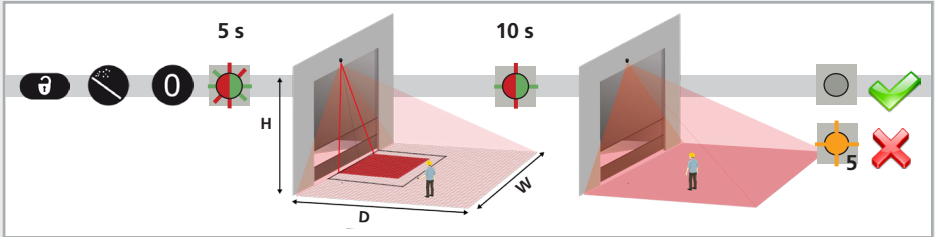

1. Launch a teach-in by remote control. It starts after 5 seconds.
2. Wait while the position, angle, and height are learned and the background is analyzed.
3. The teach-in ends successfully. If not, refer to Troubleshooting on page 14.



Instructions for a walk teach-in may be found in the Appendix, pages 18 – 19.

### b. ASSIGN OUTPUT FUNCTIONS, OUTPUT LOGIC, AND HOLD TIMES

- using the LCD (**BEA recommends**), locate the IN-OUT menu and set desired parameters *reference the LZR-WIDESCAN MENU TREE (75.5982)*
- using the remote control – see page 9

### c. PROGRAM FIELD SETTINGS

Program all desired field settings according to pages 10 – 11.

### d. PROGRAM ADDITIONAL SETTINGS

Program any additional settings:

- Pull-Cord (see page 12)
- Heating function (see page 12)
- Height Trigger (see page 13)
- Speed Trigger (see page 13)



## OUTPUT FUNCTIONS, OUTPUT LOGIC, HOLD TIMES

When programming each of the parameters listed below (function, logic, holdtime), you must always enter 3 digits for the given parameter (output 1, output 2, relay). *If you do not want to change the setting of an output, select 0.*

- 1st digit = Output 1
- 2nd digit = Output 2
- 3rd digit = Relay

NOTE: You must enter all three digits quickly, as taking too long will cause the setting to time out.

FOR EXAMPLE, if you want the outputs to be Motion or Pull-Cord (Output 1), Pull-Cord (Output 2), and Safety (relay), you must push the following buttons in the following order:



	0	1	2	3	4	5	6	7	8	9
F1 Out 1 Function	no change	motion or pull-cord	presence or safety	presence	safety	pull-cord	motion + speed	motion + height	motion pull-cord safety	motion pull-cord presence
F1 Out 2 Function	no change	motion or pull-cord	presence or safety	presence	safety	pull-cord	presence + height	motion + height	motion pull-cord safety	motion pull-cord presence
F1 Relay Function	no change	motion or pull-cord	motion	presence	safety	pull-cord	motion + speed	motion + height	motion pull-cord safety	motion pull-cord presence
Out 1 Logic*				NO	NC					
Out 2 Logic*				NO	NC					
Relay Logic*		passive	active	passive: de-energized when in detection or loss of power active: energized when in detection or loss of power						
Out 1 Holdtime	100 ms	1 s	3 s	5 s	10 s	30 s	1 min	5 min	10 min	20 min
Out 2 Holdtime	100 ms	1 s	3 s	5 s	10 s	30 s	1 min	5 min	10 min	20 min
Relay Holdtime	100 ms	1 s	3 s	5 s	10 s	30 s	1 min	5 min	10 min	20 min

## OPTIONAL REMOTE SETTINGS

	0	1	2	3	4	5	6	7	8	9
Service Mode	The service mode deactivates the presence and safety detection during 15 minutes and can be useful during an installation, a mechanical teach-in of the door, or maintenance work. Exit the service mode using the same sequence.									
Factory Reset	full: complete reset of all values partial: reset of all values except IN/OUT								full	partial
Red Spots	Pressing "magic wand" twice activates the 2 visible laser spots, enabling angle adjustments and sensor positioning.									

# OPTIONAL REMOTE CONTROL FIELD SETTINGS



Always press the UNLOCK button before entering the function and setting.

- 0
- 1
- 2
- 3
- 4
- 5
- 6
- 7
- 8
- 9



## MOTION

- C** Field width X X X 000 (min) – 460 (max)
- D** Field depth (stop) X X X 000 (min) – 460 (max)
- B** Field start X X X 000 (min) – 460 (max)

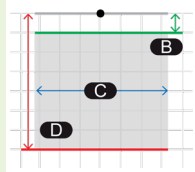

- Object type** vehicle XL: detects large vehicles; rejects bicycles & narrow forklifts vehicle XL vehicle
- vehicle: detects all types of vehicles; rejects pedestrians
- any: detects all objects

- Direction** ANY  UNI REV  UNI

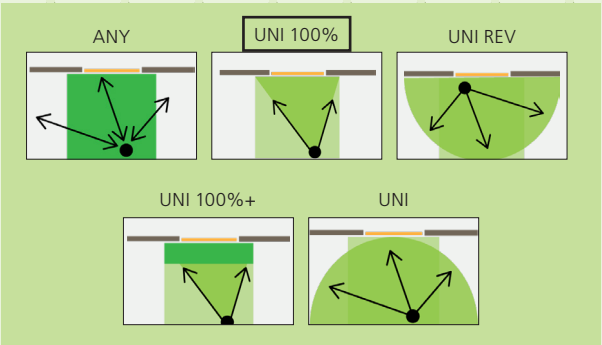

1	ANY	bidirectional detection – approaching and going away
2	<b>UNI 100% (default)</b>	unidirectional detection – approaching with cross traffic rejection
6	UNI REV	unidirectional detection with inversion – only going away
7	UNI 100%+	unidirectional detection – approaching with cross traffic rejection <i>+1m in front of door: bidirectional detection without cross traffic rejection</i>
9	UNI	unidirectional detection – approaching in any direction (distance between object and sensor decreases)

- Immunity**

# OPTIONAL REMOTE CONTROL FIELD SETTINGS (cont.)



Always press the UNLOCK button before entering the function and setting.

## PRESENCE

	0	1	2	3	4	5	6	7	8	9
<b>C</b> Field width	X X X	000 (min) – 460 (max)			240 in					
<b>D</b> Field depth (stop)	X X X	000 (min) – 460 (max)			080 in					
<b>B</b> Field start	X X X	000 (min) – 460 (max)			000 in					
<b>Object type</b>	vehicle XL: detects large vehicles; rejects bicycles & narrow forklifts vehicle: detects all types of vehicles; rejects pedestrians any: detects all objects							vehicle XL	vehicle	any
<b>Max. presence time</b>	30 s	1 min	2 min	5 min	10 min	30 min	60 min	120 min	infinite	
<b>Immunity</b>	1	2	3	4	5					

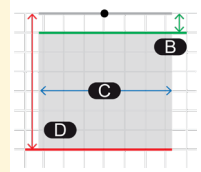

## SAFETY

	0	1	2	3	4	5	6	7	8	9
<b>C</b> Field width	X X X	000 (min) – 460 (max)			240 in					
<b>D</b> Field depth (stop)	X X X	000 (min) – 460 (max)			016 in					
<b>Max presence (for objects &lt; 1'6")</b>	30 s	1 min	2 min	5 min	10 min	30 min	60 min	120 min	infinite	
<b>Immunity</b>	1	2	3	4	5					
<b>F2</b> Uncovered Zone	2"	4"	6"	8"	An object smaller than the chosen F2 value is not detected.					

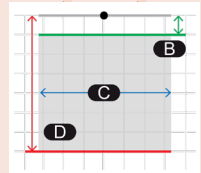

## TEACH-IN: PULL-CORD

The door only opens when an object is detected in one of the three virtual pull cord zones during the chosen min. presence time (factory value : 3 sec).



In order to use this function:

- the sensor must know its environment: teach-in install is OK
- the corresponding wires must be connected to the door activation input (relay output by default)
- the output or relay function must be set to motion or pull cord (factory value) or pull cord

To create a virtual pullcord:

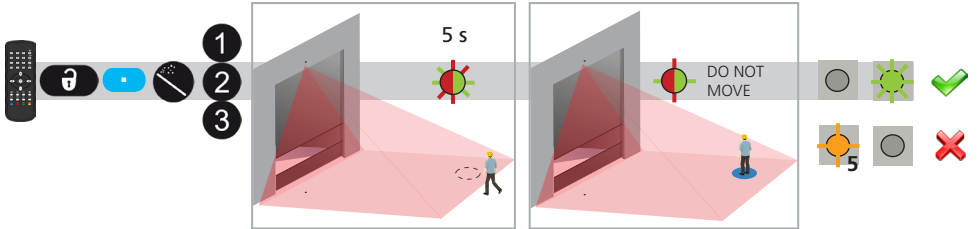

Launch a pull cord teach-in by remote control. You can create 3 different pull cords in the scanned area.

### GO TO POSITION

Go to the position where you want to activate the door by a virtual pull cord. The LED quickly flashes red-green during 5 seconds.

### DO NOT MOVE

The learning process starts, please do not move. The LED slowly flashes red-green.

The teach-in process is finalized. The LED quickly flashes green or is out.

If flashing orange see troubleshooting.

Make sure there is nothing in the scanned area!

If the LED flashes green, stop moving.

## PULL CORD SETTINGS

	Teach-in	1 # 1	2 # 2	3 # 3							
		Object type	1 pedestrian	7 vehicle XL	8 vehicle	9 any	<p>pedestrian: detects pedestrians only                  vehicle depth: detects large vehicles; rejects bicycles and narrow forklifts                  vehicle: detects all types of vehicles; rejects pedestrians                  any: detects all objects</p>				
			Min. pres. time	0 0 s	1 1 s	2 2 s	3 3 s	4 4 s	5 5 s	6 6 s	7 7 s

To delete the virtual "Pull-Cord" zone, simply relaunch a "Pull-Cord" teach-in without standing in the scanning zone. After 1 minute, the sensor flashes 5x orange. Push UNLOCK + LOCK ( ) to exit the adjustment mode.

## OPTIONAL LCD CONTROL SETTINGS

The heating function is also available via LCD. This cannot be accessed/programmed via remote control.

See the menu path below to access heating values:

MAIN → QUICK START → >MORE → OFF (default)  
 ECO  
 AUTO

The sensor draws considerably more power with the heating function ON. Reference the Technical Specifications to ensure you have enough available power.

## HEIGHT TRIGGER

By default, all objects higher than the selected value will activate the Height Trigger. This function can also be used to partially open the door depending on the height of the object.

The Height Trigger function can be used for a door control which has a partial-open input.

- Assign Output 1, Output 2, or Relay to **Motion + Height**; or assign Output 2 to **Presence + Height**.
- Connect to the Full-Open input on the door control.
- Set the motion field to any object and assign the motion to an output.
- Connect to the Partial-Open input of the door control.

*The factory default for this parameter is 7'6", but additional parameters are available by accessing the Height Limit parameter in the OTHERS menu, via LCD only – customization of this parameter is unavailable via remote control. Follow the LCD menu path to make changes:*

MAIN ➔ OTHERS ➔ HEIGHT LIMIT ➔ 68.9, 78.7, **88.6**, 98.4, 108.3, 118.1, 127.9, 137.3, 157.5

(factory default is bold/underlined)

**NOTE:** Each of these available parameters is **higher than** XX inches. I.e. If the parameter 108.4 is chosen, the sensor will detect objects with a MINIMUM height of 108.4 inches.

lower than 7'6"



The door opens partially.  
(motion detection)

higher than 7'6"

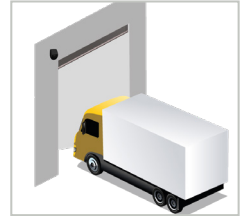

The door opens completely.  
(height detection)

## SPEED TRIGGER

By default, all objects that move slower than the selected value will activate the output.

This function helps to trigger the door open in the case of late / slow-moving objects in close proximity to the door.

*The factory default for this parameter is less than 3 mph, but additional parameters are available by accessing the Speed Limit parameter in the «OTHERS» menu, via LCD only – customization of this parameter is unavailable via remote control. Follow the LCD menu path to make changes:*

MAIN ➔ OTHERS ➔ SPEED LIMIT ➔ **3.1**, 6.2, 9.3, 12.4, 15.5, 18.6, 21.7, 24.8, 28, 31, (factory default is bold/underlined)

**NOTE:** Each of these available parameters is **slower than** XX mph. I.e. If the parameter 15.5 is chosen, the sensor will detect objects moving at speeds SLOWER than 15.5 mph.

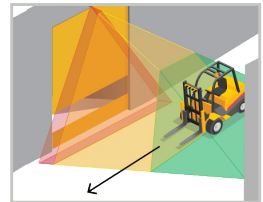
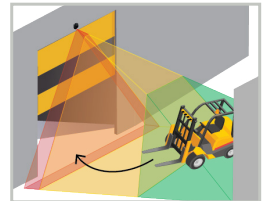

## 5 CLOSING THE SENSOR

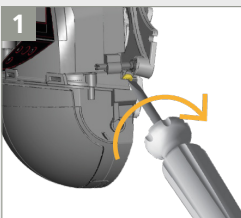

1 Lock the sensor position by firmly fastening the angle lock screw.

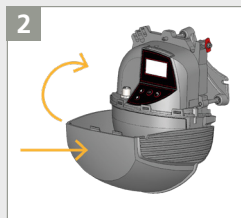



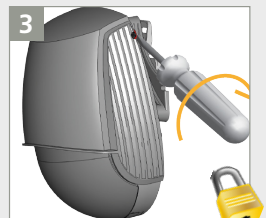











2 Reclip the sensor cover **horizontally** and close it as indicated.



3 Lock the cover by turning the lock screw clockwise.

## TROUBLESHOOTING

E1		E1: CPU-XXX	The sensor encounters an internal problem	Replace sensor.
		E2: XXX PWR	The internal power supply is faulty	Replace sensor.
E2		E2: IN SUPPLY	The power supply is too low or too high	Verify power supply (Diagnostics > LCD).
		E2: TEMP	The internal temperature is too low or too high	Verify the sensor temperature (Diagnostics > LCD). Protect the sensor from direct exposure to heat or cold.
E5			The sensor requests a teach-in	Launch teach-in after angle adjustment. All presence/safety outputs are activated.
		E5: FLATNESS	Faulty teach-in	Make sure that the teach-in zone is clear of objects and then launch install teach-in.
		E5: TILT	Faulty teach-in due to tilt angle	Adjust tilt angle (max. 15° > Diagnostics > LCD). Launch install teach-in.
		E5: AZIMUTH	Faulty teach-in due to lateral angle	Adjust lateral angle (max. 45° > Diagnostics > LCD). Launch install teach-in.
		E5: HEIGHT	Faulty teach-in due to mounting height	Adjust mounting height (max. 32', min. 6'6"). Launch install teach-in.
		E5: TIME-OUT	Faulty teach-in	Relaunch install teach-in. Make sure that there is no motion detection during at least 5 seconds when LED starts flashing red/green. Slightly change your position and relaunch an install teach-in.
E6		E6: FQ OUT	Faulty sensor output 1	Replace sensor.
E8		E8: ...	Faulty detection engine	If internal temperature is lower than 68 °F, wait until the heating process is completed. If temperature is higher than -4 °F, replace the sensor.
			ORANGLE LED is on	The sensor encounters a memory problem
		ORANGLE LED is on during 3 sec. (masking)	Sensor placed in a corner and perpendicular to a wall Masking: obstacle high up in front of door	Tilt sensor to shift detection field. Ignore warning:   Reduce number of curtains (QUICK START > MORE > Nb curtains). Ignore warning:  
			LED and LCD display are off	Incorrect wiring
		Door does not react	Service mode is activated	Exit service mode (see page 9).
		Product does not react to remote control	Sensor is password-protected	Enter correct password. If you forgot the code, cut and restore power supply in order to access the sensor without entering a password during 1 minute.
		Motion detection starts too late	Negative angle is too large	Reduce angle of the sensor.

Can't find your answer? Visit [BEAsensors.com](https://BEAsensors.com) or scan QR code for Frequently Asked Questions!



## TECHNICAL SPECIFICATIONS

<b>Technology</b>	LASER scanner, time-of-flight measurement (7 laser curtains)	
<b>Detection mode</b>	Motion, presence, height, and speed	
<b>Max. detection field</b>	Width: 1.2 × mounting height Depth: 1.2 × mounting height	<i>adjustable, depending on user settings</i>
<b>Thickness of first curtain</b>	¼ inch	
<b>Typ. mounting height</b>	6'6" – 32'	
<b>Min. reflectivity factor</b>	> 2 % (of floor and object) (measured at max. 19'6" in safety field)	
<b>Typ. min. object size</b>	6" @ 19'6" (in proportion to object distance)	
<b>Testbody</b>	27 ½" × 11 ¾" × 7 ¾"	
<b>Emission characteristics</b>		
<b>IR laser:</b>	wavelength 905 nm; output power 0.10mW (CLASS 1)	
<b>Red visible laser:</b>	wavelength 635 nm; output power 0.95mW (CLASS 2)	
<b>Supply voltage</b>	12 – 24 VAC -10/+20%	12 – 30 VDC ±10% @ sensor terminal
<b>Power consumption</b>	< 2.5 W (heating: off)	< 10 W, max 15 W (heating: eco or auto)
<b>Response time</b>	Typ. 230 ms; max. 800 ms (depending on immunity settings)	
<b>Output</b>	2 solid-state relays (galvanic isolation, polarity free) 24 VAC / 30 VDC (max. switching voltage) – 100 mA (max. switching current) - in switching mode: NO/NC - in frequency mode: pulsed signal (f= 100 Hz ±10%)  1 electro-mechanic relay (galvanic isolation, polarity free) 42 VAC/VDC (max. switching voltage) – 500 mA (max. switching current)	
<b>Input</b>	30 VDC (max. switching voltage) low < 1 V      high > 10 V (voltage threshold)	
<b>LED signals</b>	2 tri-colored LED: Output status / remote control response / error signals 1 blue LED: bluetooth status	
<b>Dimensions</b>	7 ¾" (H) x 6" (W) x 4" (D) (approx.)	
<b>Material / Color</b>	PC/ASA / Black	
<b>Rotation angles on bracket</b>	45° to the right, 15° to the left (lockable)	
<b>Tilt angles on bracket</b>	-10 – 5°	
<b>Protection degree</b>	NEMA 4 / IP65	
<b>Temperature range</b>	-22 – 140 °F	
<b>Norm conformity</b>	IEC 61000-6-2 IEC 61000-6-3 IEC 60950-1	IEC 60825-1 ISO 13849-1 Pl "d"/ CAT2 IEC 62061 SIL 2

*Specifications are subject to change without prior notice. All values measured in specific conditions.*

### BEA, INC. INSTALLATION/SERVICE COMPLIANCE EXPECTATIONS

BEA, Inc., the sensor manufacturer, cannot be held responsible for incorrect installations or incorrect adjustments of the sensor/device; therefore, BEA, Inc. does not guarantee any use of the sensor/device outside of its intended purpose.

BEA, Inc. strongly recommends that installation and service technicians be AAADM-certified for pedestrian doors, IDA-certified for doors/gates, and factory-trained for the type of door/gate system.

Installers and service personnel are responsible for executing a risk assessment following each installation/service performed, ensuring that the sensor/device system performance is compliant with local, national, and international regulations, codes, and standards.

Once installation or service work is complete, a safety inspection of the door/gate shall be performed per the door/gate manufacturer's recommendations and/or per AAADM/ANSI/DASMA guidelines (where applicable) for best industry practices. Safety inspections must be performed during each service call – examples of these safety inspections can be found on an AAADM safety information label (e.g. ANS/DASMA 102, ANS/DASMA 107, UL294, UL325, and International Building Code).

Verify that all appropriate industry signage, warning labels, and placards are in place.



Tech Support & Customer Service: 1-800-523-2462

General Tech Questions: [techservices-us@BEAsensors.com](mailto:techservices-us@BEAsensors.com) | Tech Docs: [www.BEAsensors.com](http://www.BEAsensors.com)

# APPENDIX



## FORMER HARNESSSES

### Previous EU harness

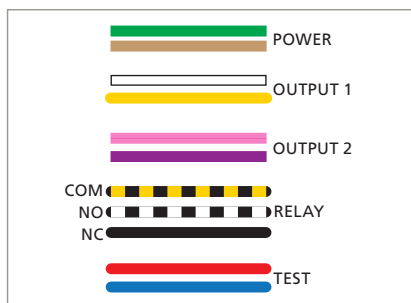

### Previous US harness

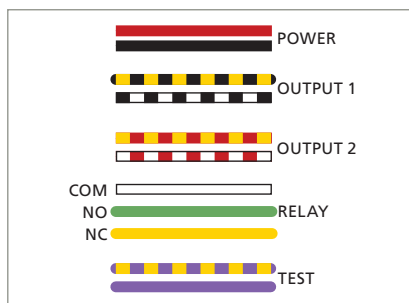

## HOW TO ADJUST THE SENSOR BY LCD



Enter the LCD menu.  
Select a folder, parameter, or value.  
Confirm a value and exit edit mode.



Return to previous menu or display.



Activate red spots on floor.



Scroll up or down.



Launch POSITION WIZARD.



Select your **Language** before entering the first LCD menu.  
*Within the first 30 seconds of power-on of the sensor or later in the diagnostics menu.*



Enter a **Password** if necessary.



Access advanced adjustments.



Go to the **Diagnostics** menu.

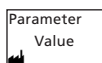

Displayed value = Factory value



Displayed value = Saved value



### QR code via LCD: Diagnostics > QR code

To quickly send an overview of all selected values, scan the QR code on the LCD screen using a smartphone scanner app. If needed, use the flashlight of your phone to improve contrast. A string of digits will appear on your phone. Send this string via email to our technical support team.

# HOW TO ADJUST THE SENSOR BY REMOTE CONTROL



After unlocking, the red LED flashes and the sensor can be adjusted by remote control.



If the red LED flashes quickly after unlocking, enter an access code from 1 to 4 digits. If you do not know the access code, **cycle power**.



To end an adjustment session, always lock the sensor.

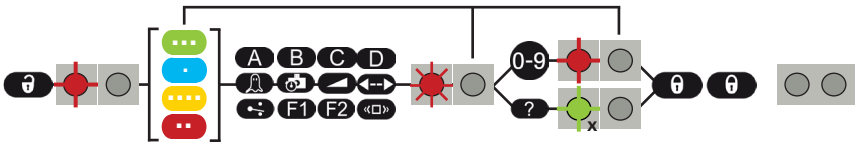

If necessary, select the corresponding detection field before selecting the parameter and changing the value. The second LED indicates the detection field.

$x = \text{number of flashes} = \text{value of parameter}$   
 = field width 2.35m

- MOTION
- PULL-CORD
- PRESENCE
- SAFETY

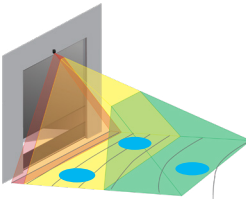

Activate red spots on floor	
Teach-in: install	
Teach-in: pull-cord	
Presettings	
Restoring	

To save an access code via the remote control:



To delete an access code via the remote control:



Enter the existing code  
 If the access code is unknown, cycle power to delete the existing access code.

**A** Field shift:  
 Always verify the detection area after changing this parameter.



**C** Without selecting a color key, all 3 detection field widths (motion, presence, and safety) are adjusted at the same time.

## TEACH-IN: WALK

You can also reshape one or more detection fields by walking around the requested field (steps 1 – 3). It is possible to cut into the existing field from the border or to extract a field within the detection field (step 4).



**Make sure the field is larger than desired. The existing field size can be reduced and adapted, but cannot exceed the configured size.**

### 1 LAUNCH A WALK TEACH-IN

Choose the desired field(s) by LCD or remote control:

	LEFT LED	
Quick Start > TeachIn > Walk All: Motion, Presence, and Safety field		1
Quick Start > TeachIn > Walk Motion: Motion field only		1
Quick Start > TeachIn > Walk Presence: Presence field only		1
Quick Start > TeachIn > Walk Safety: Safety field only		1

### 2 GO TO STARTING POINT

60 SEC / 5 SEC

Step away from the detection field and remove any objects (ladder, tools etc).

Go to the starting position of your detection field (see 1st picture below).



*The delay after which the teach-in is launched is 60 seconds by LCD (adjustable to 30 or 120 sec via Quick Start > More > TeachInDelay). **The delay by remote control is 5 seconds.***

### 3 DO NOT MOVE

The sensor learns its background as long as the LED flashes red-green.

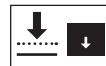

*continued on next page...*

4 START WALKING

When LED flashes green, hold one arm in the air and slowly start walking the trace of the desired field shape. Then, stop and wait until LED stops flashing.



CUT-OUT

START outside of the max. detection field.  
STOP outside the max. detection field.

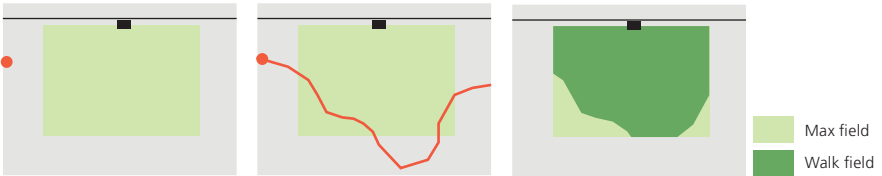

EXTRACT

START anywhere in the max. detection field.  
STOP close to the starting point.

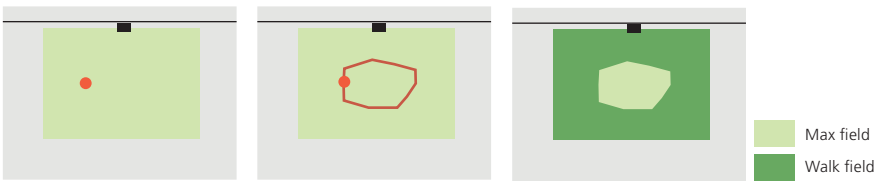

The teach-in was either successful or not (see TROUBLESHOOTING).



ADD TRACE / INVERT FIELD:



Using the remote control, you can add a trace of the field shape to all fields or one in particular (step 1).

You can invert each detection field (i.e. make the inactive side of the walked trace active) via LCD (Motion/Presence/Safety > More > Field inversion) or remote control (see pages 10 – 11). See image to the right for inversion of the field pictured above (bottom right). This feature is only available after a walk teach-in; standard setting will not allow for field inversion.



Always verify the field dimensions via the Field Display option on the LCD screen (Diagnostics > FieldDisplay).

To delete a trace, simply relaunch a walk teach-in and clear the respective detection zone for 15 seconds.